



# USER MANUAL SR30-D1

Next level digital secondary standard  
pyranometer

compliant with IEC  
61724-1:2017 Class A



## Warning statements



This manual supports model SR30-D1, the predecessor of SR30-M2-D1. Need support for the new SR30-M2-D1? Please refer to its separate user manual.



When SR30-D1 is installed using the recommended SR30-M2-D1 wiring scheme, SR30-D1 RS-485 communication will NOT function reliably.



When SR30-M2-D1 is installed using the recommended SR30-D1 wiring scheme, users will NOT benefit from improved signal integrity.



Putting more than 30 Volt across the sensor wiring of the main power supply can lead to permanent damage to the sensor.



For proper instrument grounding: use SR30-D1 with its original factory-made cable.



Using the same Modbus address for more than one device will lead to irregular behaviour of the entire network.



Do not operate with heater [ON] and ventilator [OFF]: secondary standard specifications may not be met.



Disconnect power while performing service or maintenance.

Modbus<sup>®</sup> is a registered trademark of Schneider Electric, licensed to the Modbus Organization, Inc.

# Contents

<b>Warning statements</b>	<b>2</b>
<b>Contents</b>	<b>3</b>
<b>List of symbols</b>	<b>5</b>
<b>Introduction</b>	<b>6</b>
<b>1 Ordering and checking at delivery</b>	<b>12</b>
1.1 Ordering SR30-D1	12
1.2 Included items	13
1.3 Quick instrument check	13
<b>2 Instrument principle and theory</b>	<b>14</b>
2.1 Operating modes: heating and ventilation	18
2.2 Overview of remote diagnostics	19
2.3 Use of the tilt sensor	19
<b>3 Specifications of SR30-D1</b>	<b>20</b>
3.1 Specifications of SR30-D1	20
3.2 Dimensions of SR30-D1	25
<b>4 Standards and recommended practices for use</b>	<b>26</b>
4.1 Classification standards	26
4.2 General use for solar radiation measurement	26
4.3 Specific use for outdoor PV system performance testing	27
4.4 Specific use in meteorology and climatology	27
4.5 General use for sunshine duration measurement	28
<b>5 Use of remote diagnostics</b>	<b>29</b>
5.1 Recommendations	29
5.2 Sensor temperature	29
5.3 Tilt angle	30
5.4 Internal relative humidity	30
5.5 Heater current	30
5.6 Ventilator current	31
5.7 Ventilator speed	31
<b>6 Installation of SR30-D1</b>	<b>32</b>
6.1 Site selection and installation	32
6.2 Installation of the sun screen	33
6.3 Installation of optional mounts	34
6.4 Installation of optional extension cable of 20 m	37
6.5 Electrical connection of SR30-D1: wiring diagram	38
6.6 Grounding and use of the shield	38
6.7 Connecting to an RS-485 network	39
6.8 Connecting to a PC	41
<b>7 Communication with SR30-D1</b>	<b>42</b>
7.1 PC communication: Sensor Manager software	42
7.2 Network communication: function codes, registers, coils	42
7.3 Network communication: getting started	51
7.4 Network communication: example master request to SR30-D1	52
<b>8 Making a dependable measurement</b>	<b>55</b>

8.1	The concept of dependability	55
8.2	Reliability of the measurement	56
8.3	Speed of repair and maintenance	57
8.4	Uncertainty evaluation	57
<b>9</b>	<b>Maintenance and trouble shooting</b>	<b>60</b>
9.1	Recommended maintenance and quality assurance	60
9.2	Trouble shooting	61
9.3	Calibration and checks in the field	63
9.4	Data quality assurance	64
<b>10</b>	<b>Appendices</b>	<b>66</b>
10.1	Appendix on cable extension / replacement	66
10.2	Appendix on tools for SR30-D1	67
10.3	Appendix on spare parts for SR30-D1	68
10.4	Appendix on the ventilator	68
10.5	Appendix on standards for classification and calibration	69
10.6	Appendix on calibration hierarchy	69
10.7	Appendix on meteorological radiation quantities	71
10.8	Appendix on ISO and WMO classification tables	72
10.9	Appendix on definition of pyranometer specifications	73
10.10	Appendix on terminology / glossary	74
10.11	Appendix on floating point format conversion	76
10.12	Appendix on function codes, register and coil overview	77
10.13	EU declaration of conformity	81

## List of symbols

### Quantities

Quantities	Symbol	Unit
Sensitivity	S	V/(W/m <sup>2</sup> )
Temperature	T	°C
Solar irradiance	E	W/m <sup>2</sup>
Solar radiant exposure	H	W·h/m <sup>2</sup>
Time in hours	h	h
Tilt angle relative to horizontal	$\theta_h$	°
Relative humidity	RH	%
Pressure	p	bar
Temperature coefficient	a	1/°C <sup>2</sup>
Temperature coefficient	b	1/°C
Temperature coefficient	c	-

(see also appendix 10.7 on meteorological quantities)

### Subscripts

Not applicable

## Introduction

Welcome to the next level in solar radiation monitoring! The all-digital SR30-D1 pyranometer offers the highest accuracy and highest data availability: using new Recirculating Ventilation and Heating (RVH™) technology, SR30-D1 outperforms all pyranometers equipped with traditional ventilation systems. SR30-D1 is the ideal instrument for use in PV system performance monitoring and meteorological networks.



This manual supports model SR30-D1, the predecessor of SR30-M2-D1. Need support for the new SR30-M2-D1? Please refer to its separate user manual.

SR30-D1 measures the solar radiation received by a plane surface, in  $W/m^2$ , from a  $180^\circ$  field of view angle. SR30-D1 is an ISO 9060 secondary standard pyranometer. It is employed where the highest measurement accuracy is required. SR30-D1 offers several advantages over competing pyranometers:

- Heated for best data availability: new RVH™ technology outperforms traditional pyranometer ventilation
- The first pyranometer compliant in its standard configuration with the requirements for Class A monitoring systems of the new IEC 61724-1:2017 standard
- Low cost of ownership: remote diagnostics and supported by an efficient worldwide calibration and service organisation
- The right paperwork: instruments are supplied with the ISO 9060 required test certificates



**Figure 0.1** SR30-D1 next level digital secondary standard pyranometer

### Heated for high data availability, featuring new RVH™ technology

High data availability is attained by heating of the outer dome using ventilation between the inner and outer dome. RVH™ - Recirculating Ventilation and Heating - technology, developed by Hukseflux, suppresses dew and frost deposition and is as effective as traditional ventilation systems, without the maintenance hassle and large footprint.

- low power consumption: SR30-D1 requires only 2 W, compared to 10 W for traditional ventilation systems
- low maintenance: SR30-D1 does not require filter cleaning

RVH™ uses SR30-D1's built-in heater and ventilator. The dome of SR30-D1 pyranometer is heated by ventilating the area between the inner and outer dome. RVH™ is much more efficient than traditional ventilation, where most of the heat is carried away with the ventilation air. Recirculating ventilation is as effective in suppressing dew and frost deposition at 2 W as traditional ventilation is at 10 W. RVH™ technology also leads to a reduction of zero offsets.

### Compliant with IEC 61724-1: 2017, Class A and B

IEC 61724-1: Photovoltaic System Performance Monitoring - Guidelines for Measurement, Data Exchange and Analysis - requires ventilation and heating for Class A monitoring. Only SR30 offers both, without the need for additional accessories. Most competing pyranometers do not even comply with Class B, which requires heating.

### Low cost of ownership

SR30-D1 is an affordable secondary standard instrument and is designed for low cost of ownership, which is mainly determined by costs of installation, on-site inspections, servicing and calibration:

- low demand on infrastructure, SR30-D1's RVH™ requires only 2 W power, compared to 10 W for traditional ventilation systems
- reduction of unnecessary on-site inspection by remote diagnostics
- designed for efficient servicing; easy local diagnostics
- supported by an efficient calibration and maintenance organisation. Hukseflux offers local support in the main global economies: USA, EU, China, India, Japan and Brazil. Recalibration is recommended every 2 years, which is good practice in the industry.

### Liabilities covered: test certificates

As required by ISO 9060 for secondary standard classification, each SR30-D1 is supplied with test results for the individual instrument:

- sensitivity
- directional response
- temperature response
- tilt angle measurement



**Figure 0.2** Dew deposition and frost (as in the photo): clear difference between a non-heated pyranometer (back) and SR30-D1 with RVH™ technology (front )



**Figure 0.3** Two SR30-D1 secondary standard pyranometers with digital output for GHI (global horizontal irradiance) and POA (plane of array) measurement applications

### Remote sensor diagnostics

Besides solar radiation, SR30-D1 outputs sensor diagnostics, including:

- tilt angle
- sensor body temperature
- internal humidity
- internal pressure
- ventilator speed (RPM)
- ventilator current
- heater current

Remote diagnostics permits real-time status monitoring, reducing the need for (un)scheduled field inspections.

### Suggested use

Suggested use for SR30-D1:

- PV system performance monitoring
- scientific meteorological observations

### SR30-D1 design

SR30-D1 pyranometer employs a state-of-the-art thermopile sensor with black coated surface, two domes and an anodised aluminium body. SR30-D1 offers a digital output via Modbus RTU over 2-wire RS-485. The pyranometer dome is heated by ventilating the area between the inner and outer dome using RVH™ - Recirculating Ventilation and Heating - technology.



### Diffuse radiation measurement

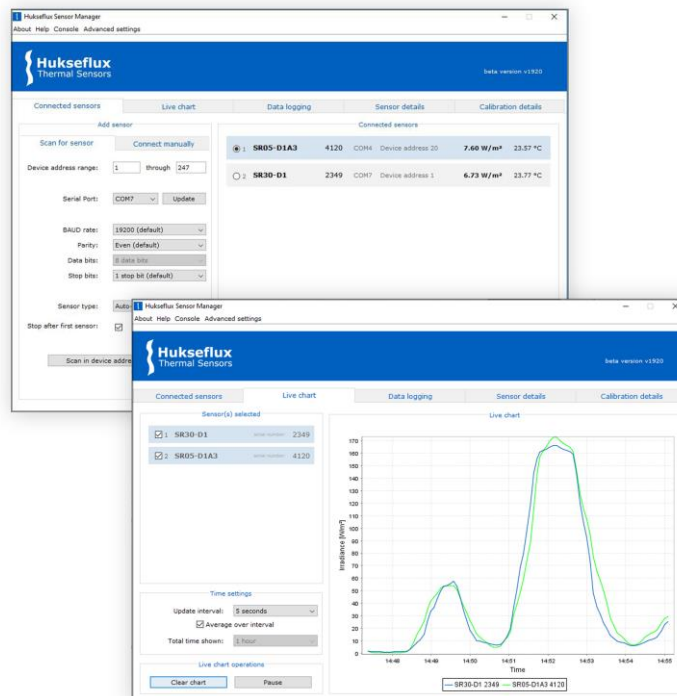
With its outstanding zero offset specifications, SR30-D1 also is the instrument of choice for high-accuracy diffuse radiation measurement.

### Operating modes: heating and ventilation

The standard operating mode of SR30-D1 is with heater and ventilator both [ON]. The power consumption then is 2.3 W. Alternatives are operation in medium power mode and in low power mode. Heating and ventilation may be switched on and off by digital control. If the heater is switched [OFF], SR30-D1 operates in medium power mode. Operation at <0.1 W, in the lower power mode, is possible by switching both the ventilator and heater [OFF]. Although zero offset will then increase slightly, overall performance will still comply with the secondary standard classification. In case there is no danger of deposition of dew or frost, the medium power mode offers the most accurate measurement.

### Communication with a PC: Hukseflux Sensor Manager Software

For communication between a PC and SR30-D1, the Hukseflux Sensor Manager software can be [downloaded](#). It allows the user to plot and export data, and change the SR30-D1 Modbus address and its communication settings. Also, the digital outputs may be viewed for sensor diagnostics. See our separate [Sensor Manager user manual](#).



**Figure 0.4** User interface of the Sensor Manager, showing sensor diagnostics

### Options for mounting and levelling

There are two mounting options available for SR30-D1: a levelling mount and a tube levelling mount. They allow for simplified mounting, levelling and instrument exchange on either a flat surface or a tube.



**Figure 0.5** Optional levelling mount (picture on the left); a practical spring-loaded mount for easy mounting, levelling and instrument exchange on flat surfaces, and the optional tube mount (picture on the right) including spring-loaded levelling upper clamp, lower clamp for tube mounting and two sets of bolts.

### Spring-loaded levelling

When opting for one of the levelling mounts, SR30-D1 is easily mounted and levelled using the mount's spring-loaded centre bolt and SR30-D1's adjustable levelling feet.



**Figure 0.6** Optional levelling mount allows spring-loaded levelling

## Cabling

The standard cable length is 5 m. Optionally cables of 10 and 20 m are supplied. Extension to longer cable lengths is achieved by adding extension cables of 20 m with 2 connectors.



**Figure 0.7** *On the left the SR30-D1 cable with M12-A female connector on sensor end, pigtails of 0.15 m and conductors with ferrules. Its length is 5 metres standard and available in 10 and 20 metres too. On the right the optional Hukseflux extension cable with connector pairs, with male and female M12-A connectors, available in 20 metres*

SR30-D1 is designed for use in SCADA (Supervisory Control And Data Acquisition) systems, supporting Modbus RTU (Remote Terminal Unit) protocol over RS-485. In these networks the sensor operates as a slave. SCADA systems are often implemented in photovoltaic solar energy (PV) systems and meteorological networks. Using SR30-D1 in a network is easy. Once it has the correct Modbus address and communication settings and is connected to a power supply, the instrument can be used in RS-485 networks. The user should have sound knowledge of the Modbus communication protocol when installing sensors in a network.

The instrument should be used in accordance with the recommended practices of ISO, WMO and ASTM.

The recommended calibration interval of pyranometers is 2 years. The registers containing the applied sensitivity and the calibration history of SR30-D1 are fully accessible for users. This allows the user to choose his own local calibration service. The same feature may be used for remotely controlled re-calibration of pyranometers in the field. Ask Hukseflux for information on this feature and on ISO and ASTM standardised procedures for field calibration.

# 1 Ordering and checking at delivery

## 1.1 Ordering SR30-D1

SR30-D1 is succeeded by model SR30-M2-D1 and can no longer be ordered. Please order SR30-M2-D1 instead. Support and recalibration services for SR30-D1 will continue.

The standard configuration of SR30-D1 is with 5 metres cable.

Common options are:

- longer cable; 10 and 20 metres
- levelling mount. Specify article number LM01
- tube levelling mount with set of bolts. Includes LM01. Specify article number TLM01
- 20 metres extension cable with 2 connectors. Specify article number C07E-20

**Table 1.1.1** Ordering codes for SR30-D1

<b>VERSIONS OF SR30-D1 (part numbers)</b>	
SR30-D1	next level digital secondary standard pyranometer, with ventilation, heating, tilt sensor and Modbus over RS-485 output
SR30-D1-LM01	next level digital secondary standard pyranometer, with ventilation, heating, tilt sensor and Modbus over RS-485 output and with levelling mount, for spring-loaded levelling and mounting SR30 on a surface
SR30-D1-TLM01	next level digital secondary standard pyranometer, with ventilation, heating, tilt sensor and Modbus over RS-485 output and with tube levelling mount, for spring-loaded levelling and mounting SR30 on a tube
<b>CABLE FOR SR30-D1, with female M12-A connector at sensor end, pigtails of 0.15 m and conductors with ferrules</b>	
`-05' after SR30-D1 part number	standard cable length: 5 m
`-10' after SR30-D1 part number	cable length: 10 m
`-20' after SR30-D1 part number	cable length: 20 m
<b>CABLE EXTENSION FOR SR30-D1, with male and female M12-A connectors</b>	
C07E-20	cable length: 20 m

An extension cable (with connector pair) can be used in combination with a regular cable (with one connector at sensor end) to make alternative SR30-D1 cable lengths possible.



This manual supports model SR30-D1, the predecessor of SR30-M2-D1. Need support for the new SR30-M2-D1? Please refer to its separate user manual.

## 1.2 Included items

Arriving at the customer, the delivery should include:

- pyranometer SR30-D1
- sun screen
- cable of the length as ordered
- product certificate matching the instrument serial number, including:
  - calibration certificate
  - temperature response test report
  - directional response test report
  - tilt sensor test report
- Hukseflux Sensor Manager software on a USB flash drive
- any other options as ordered

For SR30-D1-LM01, also

- spring-loaded levelling mount

For SR30-D1-TLM01, also

- spring-loaded levelling mount
- lower clamp to mount SR30-D1 to a tube or mounting rod
- 2 sets of bolts for different tube diameters

Please store the certificates in a safe place.

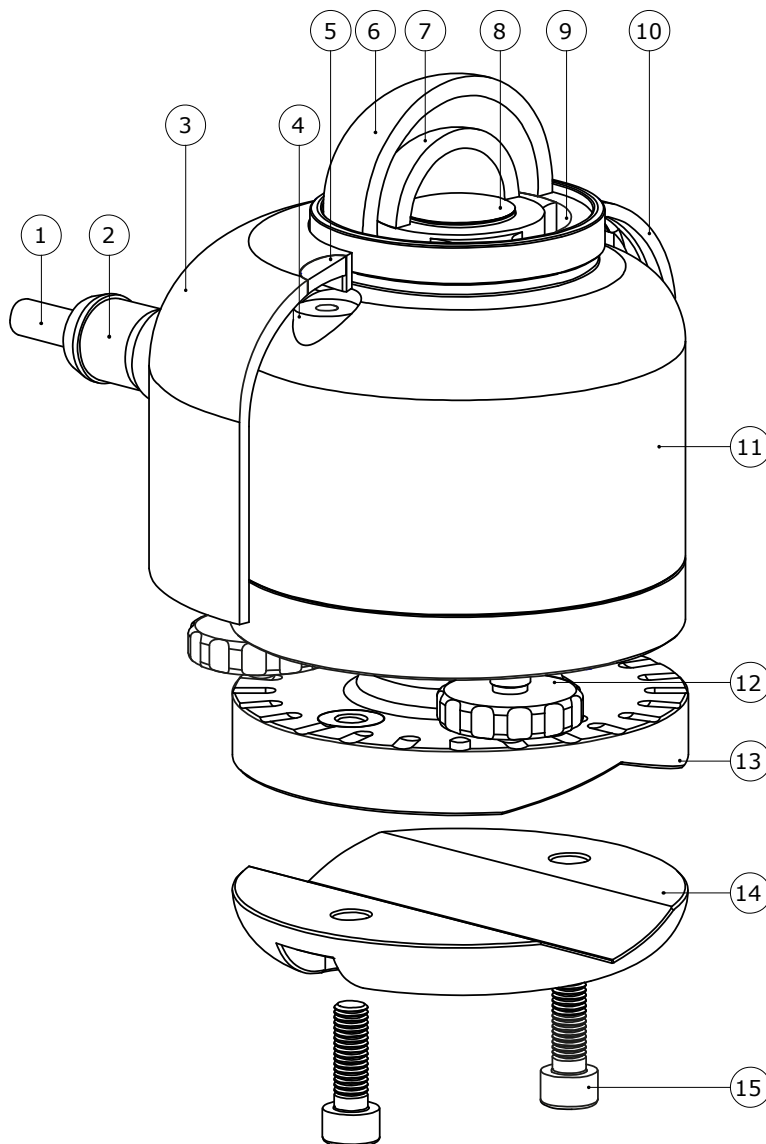
The latest version of the Hukseflux Sensor Manager can be downloaded via <https://www.hukseflux.com/downloads>.

## 1.3 Quick instrument check

A quick test of the instrument can be done by connecting it to a PC and installing the Sensor Manager software. See the chapters on installation and PC communication for directions. Please note that you will need a separate power supply; the sensor cannot be powered from the USB only.

1. At power-up the signal may have a temporary output level different from zero; an offset. Let this offset settle down; it is a normal part of the power-up procedure.
2. Check if the sensor reacts to light: expose the sensor to a strong light source, for instance a 100 W light bulb at 0.1 m distance. The signal should read  $> 100 \text{ W/m}^2$  now. Darken the sensor either by putting something over it or switching off the light. The instrument irradiance output should go down and within one minute approach  $0 \text{ W/m}^2$ .
3. Inspect the bubble level, compare to the tilt angle output.
4. Verify heater current, ventilator speed, internal humidity.
5. Inspect the instrument for any damage.
6. Check the instrument serial number as indicated by the software against the label on the instrument and against the certificates provided with the instrument.

## 2 Instrument principle and theory



**Figure 2.0.1** Overview of SR30-D1:

- (1) cable (standard length 5 metres, optional longer cable)
- (2) connector
- (3) sun screen
- (4) bubble level
- (5) bubble level window
- (6) outer dome
- (7) inner dome
- (8) thermal sensor with black coating
- (9) internal ventilation vents
- (10) quick release system of sun screen
- (11) instrument body
- (12) levelling feet
- (13) optional spring-loaded levelling mount
- (14) optional tube mount
- (15) screws included with tube mount

SR30-D1's scientific name is pyranometer. A pyranometer measures the solar radiation received by a plane surface from a 180 ° field of view angle. This quantity, expressed in W/m<sup>2</sup>, is called "hemispherical" solar radiation. The solar radiation spectrum extends roughly from 285 to 3000 x 10<sup>-9</sup> m. By definition a pyranometer should cover that spectral range with a spectral selectivity that is as "flat" as possible.

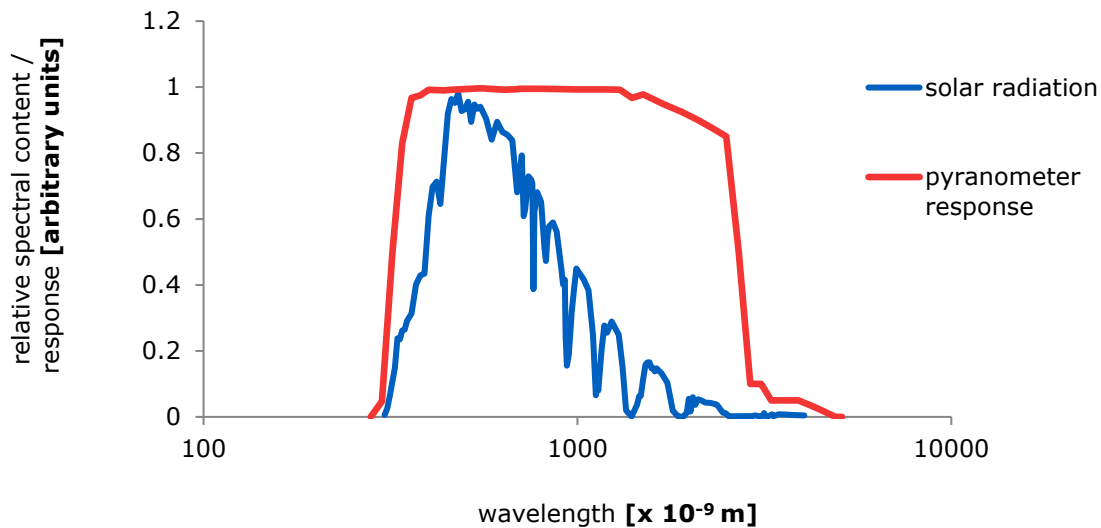
In an irradiance measurement by definition the response to "beam" radiation varies with the cosine of the angle of incidence; i.e. it should have full response when the solar radiation hits the sensor perpendicularly (normal to the surface, sun at zenith, 0 ° angle of incidence), zero response when the sun is at the horizon (90 ° angle of incidence, 90 ° zenith angle), and 50 % of full response at 60 ° angle of incidence. A pyranometer should have a so-called "directional response" (older documents mention "cosine response") that is as close as possible to the ideal cosine characteristic.

In order to attain the proper directional and spectral characteristics, SR30-D1's main components are:

- a thermal sensor with black coating. It has a flat spectrum covering the 200 to 50000 x 10<sup>-9</sup> m range, and has a near-perfect directional response. The coating absorbs all solar radiation and, at the moment of absorption, converts it to heat. The heat flows through the sensor to the sensor body. The thermopile sensor generates a voltage output signal that is proportional to the solar irradiance.
- in case of SR30-D1, the analogue thermopile voltage is converted by the instrument electronics to a digital signal. In this process the temperature dependence of the thermopile is compensated. SR30-D1 uses a high-end 24-bit A/D converter.
- a glass dome. This dome limits the spectral range from 285 to 3000 x 10<sup>-9</sup> m (cutting off the part above 3000 x 10<sup>-9</sup> m), while preserving the 180 ° field of view angle. Another function of the dome is that it shields the thermopile sensor from the environment (convection, rain).
- a second (inner) glass dome: For a secondary standard pyranometer, two domes are used, and not one single dome. This construction provides an additional "radiation shield", resulting in a better thermal equilibrium between the sensor and inner dome, compared to using a single dome. The effect of having a second dome is a strong reduction of instrument offsets.
- a heater and ventilator: in order to reduce dew deposition and frost on the outer dome surface, SR30-D1 has a built-in heater and ventilator. The heater is coupled to the sensor body. The ventilation air circulates inside the body and between the domes. The combination of ventilation and heating keeps the domes in thermal equilibrium with the sensor and above dew point. When ventilation is [ON], zero offsets are very low.
- a tilt sensor: this sensor measures tilt with a ± 1 ° uncertainty and a short-term resolution, or detection limit, of better than 0.1 °. This is sufficient to monitor incidents that change the instrument tilt.

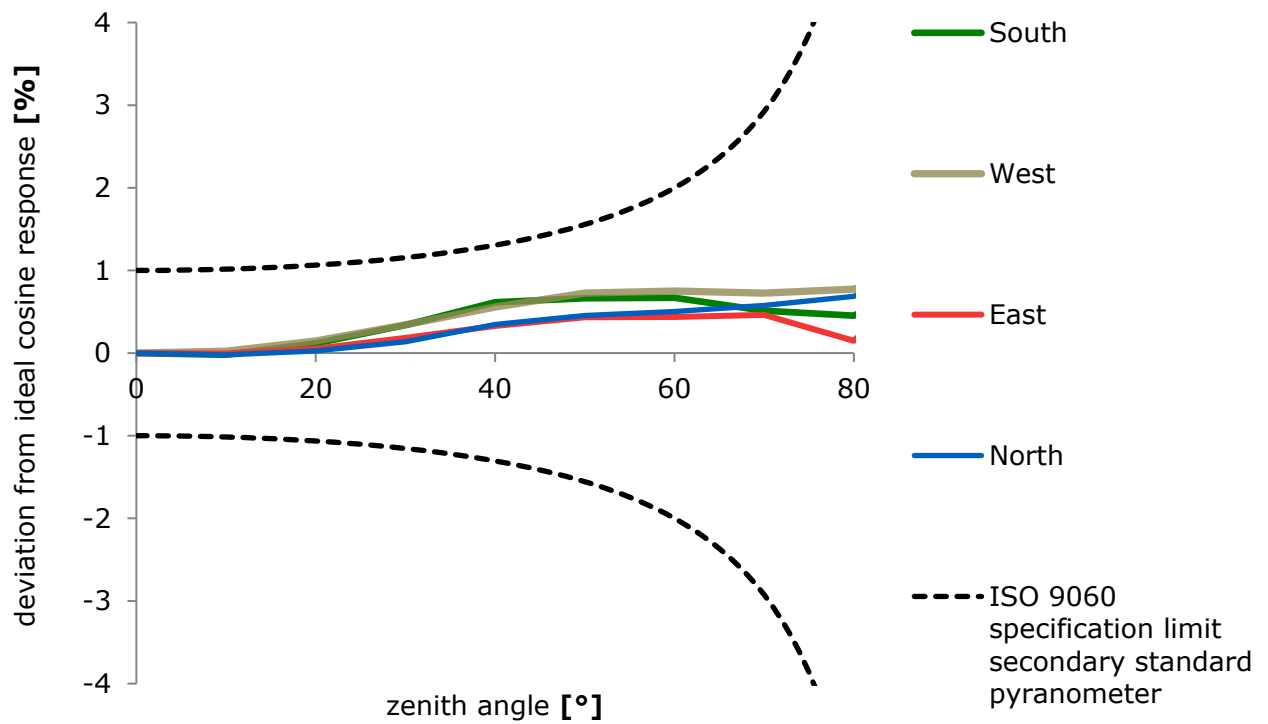
Pyranometers can be manufactured to different specifications and with different levels of verification and characterisation during production. The ISO 9060 - 1990 standard, "Solar energy - specification and classification of instruments for measuring hemispherical solar and direct solar radiation", distinguishes between 3 classes; secondary standard (highest accuracy), first class (second highest accuracy) and second class (third highest accuracy).

From second class to first class and from first class to secondary standard, the achievable accuracy improves by a factor 2.

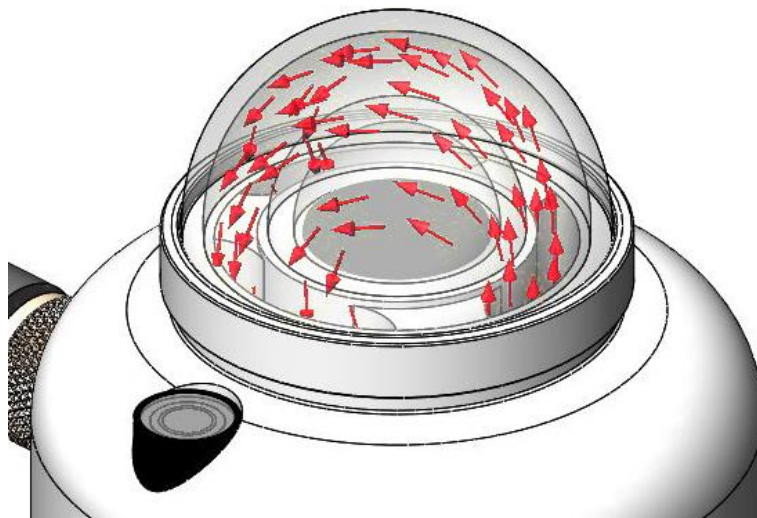


**Figure 2.0.2** Spectral response of the pyranometer compared to the solar spectrum. The pyranometer only cuts off a negligible part of the total solar spectrum.





**Figure 2.0.3** Directional response of an SR30-D1 pyranometer of 4 azimuth angles, compared to secondary standard limits.



**Figure 2.0.4** Recirculating ventilation and heating between the inner- and outer dome is much more power-efficient than traditional ventilation systems.

## 2.1 Operating modes: heating and ventilation

A unique feature of SR30-D1 is its built-in heater and ventilator. In practice, this is as effective against dew and frost deposition as using traditional ventilation systems.

The heater is coupled to the sensor body. Heat is generated inside the sensor body. The ventilator circulates air inside the body and between the domes. The combination of ventilation and heating keeps the domes in thermal equilibrium with the sensor and the entire instrument above dew point. When ventilation is [ON], zero offsets are very low.

There are 3 operation modes: standard, medium power and low power mode. In standard operating mode, both heater and ventilator are [ON], in medium power mode, only the ventilator is [ON], in low power mode both are [OFF]. Table 2.1.1 gives an overview of these settings and our recommendations for use.

**Table 2.1.1** Possible user scenarios for the heater and ventilator

Operating mode	heater status	ventilator status	power use (nominal)	comment
standard	[ON]	[ON]	2.3 W	factory default recommended settings
N/A	[ON]	[OFF]		do not use these settings, secondary standard specifications will not be met
medium power	[OFF]	[ON]	0.6 W	this mode offers the most accurate measurement results because the sensitivity to thermal fluctuations of the environment is smaller recommended over the [OFF] [OFF] setting, because it reduces the thermal sensor offset
low power	[OFF]	[OFF]	0.1 W	secondary standard performance is also guaranteed with these settings

Heating when used in combination with ventilation does not affect the classification specifications and the measurement accuracy.

When using the heater without ventilation secondary standard specifications will not be met, because of a heating-induced offset.

In case that there is no danger of deposition of dew or frost, the medium power mode (using the ventilator but not the heater) offers the most accurate measurements over short time intervals. Averages on the minute time scale produce the same result as in the standard operating mode. The measurement in medium power mode is less sensitive to thermal shocks, and is less noisy.

The ventilator power is around 0.5 W. Typical heater power is 1.7 W. With around 0.1 W power to the electronics, the total power consumption is approximately 2.3 W.

## 2.2 Overview of remote diagnostics

Besides the digital output measuring irradiance in W/m<sup>2</sup>, SR30-D1 has several sensors giving outputs which may be used for remote diagnostics. Remote monitoring of the sensor condition helps improve the accuracy and reliability of the measurement. It also allows to improve preventive maintenance and effective trouble shooting. Chapter 5 gives recommendations on how to use these diagnostics. Chapter 7 contains details on the register structure, needed for reading the remote diagnostics output.

A brief overview of the diagnostic signals and their respective registers:

- Tilt angle, "tilt angle average" register
- Sensor body temperature, "sensor body temperature" register
- Internal humidity, "humidity" register
- Internal pressure, "pressure average" register
- Ventilator speed, "fan speed RPM" register
- Ventilator current, "fan current" register
- Heater current, "heater current" register

## 2.3 Use of the tilt sensor

SR30-D1 is equipped with an internal tilt sensor. The tilt measurement serves to monitor long-term changes as well as incidents that cause the instrument to move. The absolute accuracy of the sensor depends on temperature and is not as high as that of the bubble level. The bubble level remains the reference for horizontal installation. The short-term resolution, or detection limit, of the tilt sensor is sufficiently high for monitoring possible incidents. Table 2.3.1 gives recommendations for using the tilt sensor.

**Table 2.3.1** Recommendations for use of the tilt sensor

Application	Required accuracy	Reference	Remarks
Tilted installation	$\pm 1^\circ$	tilt sensor	tilt measurement is sufficiently accurate
Horizontal installation	$\pm 0.1^\circ$	bubble level	tilt measurement is not sufficiently accurate
Short-term incident monitoring	$\pm 0.1^\circ$	tilt sensor output, immediately after installation	after levelling with the bubble level, store "tilt angle average" register. This stored measurement is the reference for monitoring incidents. for short-term incident monitoring, mark changes or generate a warning if the tilt sensor measurement exceeds 0.2 °/ min.
Long term monitoring	$\pm 1^\circ$	tilt sensor output, immediately after installation	for long term monitoring, mark changes or generate a warning if the tilt sensor measurement exceeds 1 °.

## 3 Specifications of SR30-D1

### 3.1 Specifications of SR30-D1

SR30-D1 measures the solar radiation received by a plane surface from a 180 ° field of view angle. This quantity, expressed in W/m<sup>2</sup>, is called "hemispherical" solar radiation. SR30-D1 offers irradiance in W/m<sup>2</sup> as a digital output. It must be used in combination with suitable power supply and a data acquisition system which uses the Modbus communication protocol over an RS-485 connection. When operated with both heater and ventilator [ON] or both [OFF], or with only the ventilator [ON] the instrument is classified as secondary standard according to ISO 9060. It should be used in accordance with the recommended practices of ISO, IEC, WMO and ASTM.



This manual supports model SR30-D1, the predecessor of SR30-M2-D1. Need support for the new SR30-M2-D1? Please refer to its separate user manual.

**Table 3.1.1** *Specifications of SR30-D1 (continued on next pages)*

<b>SR30-D1 MEASUREMENT SPECIFICATIONS: LIST OF CLASSIFICATION CRITERIA OF ISO 9060*</b>	
ISO classification (ISO 9060:1990)	secondary standard pyranometer
WMO performance level (WMO-No. 8, seventh edition 2008)	high quality pyranometer
Response time (95 %)	3 s
Zero offset a (response to 200 W/m <sup>2</sup> net thermal radiation)	
- in standard operating mode	2 W/m <sup>2</sup>
- in medium power mode	2 W/m <sup>2</sup>
- in low power mode	5 W/m <sup>2</sup>
Zero offset b (response to 5 K/h change in ambient temperature)	< ± 2 W/m <sup>2</sup>
Non-stability	< ± 0.5 % change per year
Non-linearity	< ± 0.2 % (100 to 1000 W/m <sup>2</sup> )
Directional response	< ± 10 W/m <sup>2</sup>
Directional response test of individual instrument	report included
Spectral selectivity	< ± 3 % (0.35 to 1.5 × 10 <sup>-6</sup> m)
Temperature response	< ± 0.4 % (-30 to +50 °C)
Temperature response test of individual instrument	report included
Tilt response	< ± 0.2 % (0 to 90 ° at 1000 W/m <sup>2</sup> )
<b>IEC 61724-1:2017 COMPLIANCE</b>	
IEC 61724-1:2017 compliance	meets Class A PV monitoring system requirements meets Class B PV monitoring system requirements

\*For the exact definition of pyranometer ISO 9060 specifications see the appendix.

**Table 3.1.1** Specifications of SR30-D1 (continued)

<b>SR30-D1 ADDITIONAL SPECIFICATIONS</b>	
<b>Measurand</b>	hemispherical solar radiation
Measurand in SI radiometry units	irradiance in W/m <sup>2</sup>
Optional measurand	sunshine duration
Field of view angle	180 °
Technology employed	Recirculating Ventilation and Heating (RVH™)
Heating	included
Ventilation	included
Standard operating mode	heater and ventilator [ON]
Power consumption	< 2.3 W at 12 VDC
Output definition	running average over 4 measurements, refreshed every 0.1 s
Recommended data request interval	1 s, storing 60 s averages
Measurement range	-400 to 4000 W/m <sup>2</sup>
Zero offset steady state	< ± 1 W/m <sup>2</sup> (-40 to + 80 °C)
Measurement function / optional programming for sunshine duration	programming according to WMO guide paragraph 8.2.2
<b>Measurand</b>	sensor temperature
Sensor temperature measurement accuracy	± 0.5 °C
Rated operating temperature range	-40 to +80 °C
Spectral range (20 % transmission points)	285 to 3000 x 10 <sup>-9</sup> m
<b>Measurand</b>	sensor tilt angle
Tilt measurement uncertainty	± 1 ° (0 to 90 °)
Tilt sensor detection limit	< 0.1 ° (smallest meaningfully detectable change in a time interval of < 10 min)
Tilt sensor characterisation of individual instrument	report included
Levelling (see options)	bubble level and adjustable levelling feet are included
Levelling accuracy	< 0.1 ° bubble entirely in ring
<b>Measurand</b>	sensor internal relative humidity
Humidity sensor uncertainty	± 3 %
<b>Measurand</b>	sensor internal pressure
sensor uncertainty	± 4 mbar
<b>Measurand</b>	heater current
<b>Measurand</b>	ventilator current
<b>Measurand</b>	ventilator speed in RPM
Standards governing use of the instrument	IEC 61724-1; Photovoltaic system performance monitoring – guidelines for measurement, data exchange and analysis ISO/TR 9901:1990 Solar energy -- Field pyranometers -- Recommended practice for use ASTM G183 - 05 Standard Practice for Field Use of Pyranometers, Pyrheliometers and UV Radiometers
Standard cable length (see options)	5 m
Cable diameter	4.8 x 10 <sup>-3</sup> m
Chassis connector	M12-A straight male connector, male thread, 5-pole

**Table 3.1.1** Specifications of SR30-D1 (started on previous page)

Chassis connector type	M12-A
Cable connector	M12-A straight female connector, female thread, 5-pole
Cable connector type	M12-A
Connector protection class	IP67
Cable replacement	replacement cables with connector can be ordered separately from Hukseflux
Mounting (see options)	2 x M5 bolt at 46 mm centre-to-centre distance on north-south axis, requires 4 mm hex key 1x M6 bolt, centered
Desiccant	two bags of silica gel, 2 x 1 g
Desiccant replacement	> 5 year interval, typically replaced during calibration, ask the manufacturer for instructions
Ventilator replacement	> 5 year interval, ask the manufacturer for instructions
IP protection class	IP67
Gross weight including 5 m cable	approx. 1 kg
Net weight including 5 m cable	approx. 0.5 kg
Packaging	box of (200 x 145 x 160) mm
<b>HEATING AND VENTILATION</b>	
Heater voltage	5 V (independent of supply voltage)
Rated heater current range	0.250 to 0.375 A
Rated ventilator speed	5,000 to 10,000 RPM (uncontrolled)
<b>STANDARD OPERATING MODE</b>	
Standard operating mode	heater [ON] and ventilator [ON]
Zero offset a	< 2 W/m <sup>2</sup>
Supply voltage range	8 to 30 VDC
Power consumption	< 2.3 W
<b>MEDIUM POWER OPERATING MODE</b>	
Operating condition	heater [OFF] and ventilator [ON]
Zero offset a	2 W/m <sup>2</sup>
Supply voltage range	8 to 30 VDC
Power consumption	< 0.6 W
<b>LOW POWER OPERATING MODE</b>	
Operating condition	heater [OFF] and ventilator [OFF]
Zero offset a	5 W/m <sup>2</sup>
Supply voltage range	5 to 30 VDC
Power consumption	< 0.1 W
<b>CALIBRATION</b>	
Calibration traceability	to WRR
Calibration hierarchy	from WRR through ISO 9846 and ISO 9847, applying a correction to reference conditions
Calibration method	indoor calibration according to ISO 9847, Type IIc
Calibration uncertainty	< 1.2 % (k = 2)

**Table 3.1.1** Specifications of SR30-D1 (started on previous pages)

Recommended recalibration interval	2 years
Reference conditions	20 °C, normal incidence solar radiation, horizontal mounting, irradiance level 1000 W/m <sup>2</sup> , heater and ventilator [ON]
Validity of calibration	based on experience the instrument sensitivity will not change during storage. During use under exposure to solar radiation the instrument "non-stability" specification is applicable.
Adjustment after re-calibration	via a PC, as <i>power user</i> with the Sensor Manager software. Request "power user" status at the factory for sensitivity adjustment and for writing the calibration history data.

**MEASUREMENT ACCURACY AND RESOLUTION**

Uncertainty of the measurement	statements about the overall measurement uncertainty can only be made on an individual basis. see the chapter on uncertainty evaluation
WMO estimate on achievable accuracy for daily sums (see appendix for a definition of the measurement conditions)	2 %
WMO estimate on achievable accuracy for hourly sums (see appendix for a definition of the measurement conditions)	3 %
Irradiance resolution	0.05 W/m <sup>2</sup>
Instrument body temperature resolution	7.8 x 10 <sup>-3</sup> °C
Instrument body temperature accuracy	± 0.5 °C
Instrument tilt measurement accuracy	± 1 °

**DIGITAL COMMUNICATION**

Digital output	irradiance in W/m <sup>2</sup> instrument body temperature in °C instrument internal humidity in % instrument internal pressure in Pa instrument tilt angle in ° ventilator speed in RPM ventilator current in A heater current in A
Rated operating voltage range	8 to 30 VDC
Communication protocol	Modbus over 2-wire RS-485, half duplex
Transmission mode	RTU
Common mode range	± 25 V

**OPTIONS**

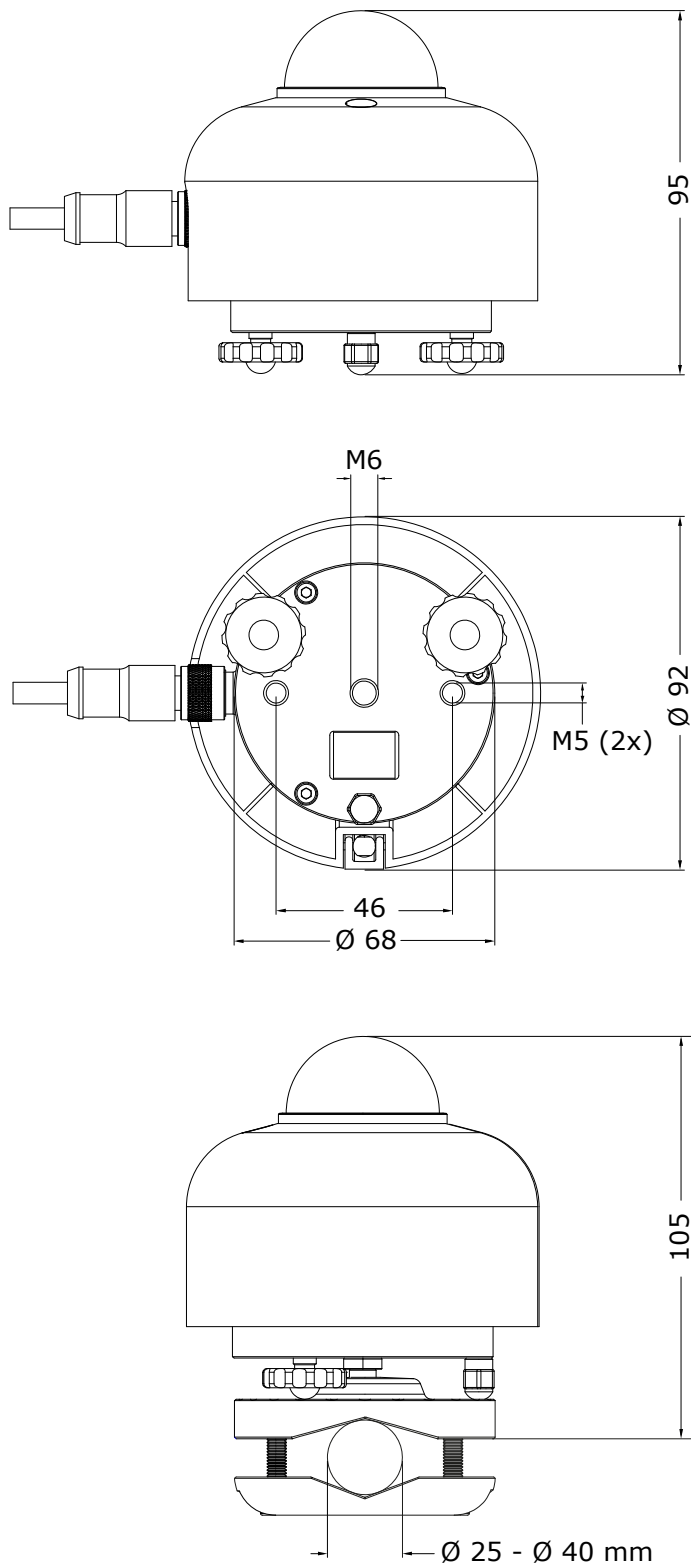
Longer cable: 10 or 20 metre length Cable with M12-A female connector on sensor end, stripped (pigtailed of 0.15 m and conductors with ferrules) on other end	option code = total cable length
Extension cable with connector pair, 20 m length; cable with male and female M12-A connectors	option code = C07E-20 for 20 metres

**Table 3.1.1** *Specifications of SR30-D1 (started on previous pages)*

<b>ACCESSORIES</b>	
Levelling mount, for spring-loaded levelling and mounting SR30-D1 on a surface	mountable on flat surface allowing tilt adjustment to 3.4 ° requires 4 mm hex key or 10 mm spanner for connecting to SR30-D1 requires two M5 bolts and hex key for mounting to a surface (not included) 2 x M5 at 46 x 10 <sup>-3</sup> m centre to centre distance option code = LM01
Tube levelling mount, for spring-loaded levelling and mounting SR30-D1 on a tube	mountable on tubes Ø 25 to Ø 40 mm one spring-loaded levelling mount, one clamp for tube mounting and two sets of bolts (two M5x30 and two M5x45) included allowing tilt adjustment to 3.4 ° requires 4 mm hex key for mounting and 4 mm hex key or 10 mm spanner for connecting to SR30-D1 option code = TLM01
Software for use with a PC	Hukseflux Sensor Manager software, version v2021 or higher. The latest software can be downloaded via <a href="https://www.hukseflux.com/downloads">https://www.hukseflux.com/downloads</a>  For a Sensor Manager user manual, please visit <a href="https://www.hukseflux.com/products/solar-radiation-sensors/pyranometers/hukseflux-sensor-manager">https://www.hukseflux.com/products/solar-radiation-sensors/pyranometers/hukseflux-sensor-manager</a>



### 3.2 Dimensions of SR30-D1



**Figure 3.2.1** Dimensions of SR30-D1 in  $\times 10^{-3}$  m. Mounts are optional

## 4 Standards and recommended practices for use

Pyranometers are classified according to the ISO 9060 standard and the WMO-No. 8 Guide. In any application the instrument should be used in accordance with the recommended practices of ISO, IEC, WMO and / or ASTM.

### 4.1 Classification standards

**Table 4.1.1** *Standards for pyranometer classification. See the appendix for definitions of pyranometer specifications, and a table listing the specification limits.*

<b>STANDARDS FOR INSTRUMENT CLASSIFICATION</b>		
ISO STANDARD	EQUIVALENT ASTM STANDARD	WMO
ISO 9060:1990 Solar energy -- specification and classification of instruments for measuring hemispherical solar and direct solar radiation	Not available	WMO-No. 8; Guide to Meteorological Instruments and Methods of Observation, chapter 7, measurement of radiation, 7.3 measurement of global and diffuse solar radiation

### 4.2 General use for solar radiation measurement

**Table 4.2.1** *Standards with recommendations for instrument use in solar radiation measurement*

<b>STANDARDS FOR INSTRUMENT USE FOR HEMISPHERICAL SOLAR RADIATION</b>		
ISO STANDARD	EQUIVALENT ASTM STANDARD	WMO
ISO/TR 9901:1990 Solar energy -- Field pyranometers -- Recommended practice for use	ASTM G183 - 05 Standard Practice for Field Use of Pyranometers, Pyrheliometers and UV Radiometers	WMO-No. 8; Guide to Meteorological Instruments and Methods of Observation, chapter 7, measurement of radiation, 7.3 measurement of global and diffuse solar radiation

### 4.3 Specific use for outdoor PV system performance testing

Pyranometers are used for monitoring PV power plant efficiency, in order to measure incoming solar radiation independently from the PV system. Pyranometers can be placed in two positions:

- plane of array (POA), parallel to the PV panels, for measurement of the in-plane irradiance (also noted as  $G_i$  in IEC 61724-1)
- horizontally, for measurement of the global horizontal irradiance ( $E$ , also noted as GHI in IEC 61724-1)

**Table 4.3.1** Standards with recommendations for instrument use in PV system performance testing

STANDARDS ON PV SYSTEM PERFORMANCE TESTING	
IEC / ISO STANDARD	EQUIVALENT ASTM STANDARD
IEC 61724-1; Photovoltaic system performance monitoring – guidelines for measurement, data exchange and analysis SR30 complies, in its standard configuration, with the IEC 61724-1:2017 requirements of Class A and Class B PV monitoring systems  COMMENT: Allows pyranometers or reference cells according to IEC 60904-2 and -6. Pyranometer reading required accuracy better than 5 % of reading (Par 4.1)  COMMENT: equals JISC 8906 (Japanese Industrial Standards Committee)	ASTM 2848-11; Standard Test Method for Reporting Photovoltaic Non-Concentrator System Performance  COMMENT: confirms that a pyranometer is the preferred instrument for outdoor PV testing. Specifically recommends a “first class” pyranometer (paragraph A 1.2.1.)

### 4.4 Specific use in meteorology and climatology

The World Meteorological Organization (WMO) is a specialised agency of the United Nations. It is the UN system's authoritative voice on the state and behaviour of the earth's atmosphere and climate. WMO publishes WMO-No. 8; Guide to Meteorological Instruments and Methods of Observation, in which a table is included on “level of performance” of pyranometers. Nowadays WMO conforms itself to the ISO classification system.

In case there is no danger of deposition of dew and frost, the medium power mode (using the ventilator but not the heater) offers the most accurate measurements over short time intervals. Averages on the minute time scale produce the same result as in the standard operating mode. The measurement is less sensitive to rapid changes of the instrument temperature, and is less noisy.

## 4.5 General use for sunshine duration measurement

According to the World Meteorological Organization (WMO, 2003), sunshine duration during a given period is defined as the sum of that sub-period for which the direct solar irradiance exceeds 120 W/m<sup>2</sup>. WMO has approved the "pyranometric method" to estimate sunshine duration from pyranometer measurements (Chapter 8 of the WMO Guide to Instruments and Observation, 2008). This implies that a pyranometer may be used, in combination with appropriate software, to estimate sunshine duration. Ask for our application note.

**Table 4.5.1** *Standards with recommendations for instrument use in sunshine duration measurement*

---

**STANDARDS FOR INSTRUMENT USE FOR SUNSHINE DURATION**

---

---

WMO

---

WMO-No. 8; Guide to Meteorological Instruments and Methods of Observation, chapter 8, measurement of sunshine duration, 8.2.2 Pyranometric Method

---

## 5 Use of remote diagnostics

Remote monitoring of the sensor condition helps improve the accuracy and reliability of the measurement. It also allows to improve preventive maintenance and effective trouble shooting. The following remote diagnostics signals are part of the digital output. It is up to the user whether or not to use these diagnostics.

Chapter 7 contains details on the register structure, needed for reading the remote diagnostics output.

### 5.1 Recommendations

For remote diagnostics, we recommend to measure and store internal sensor humidity, ventilator RPM, ventilator current, heater current and tilt angle at 24:00 local time.

We recommend to monitor short term changes of the sensor tilt, and generate a warning in case of changes  $> 0.2^\circ / \text{min}$ .

After levelling horizontally (using the bubble level) or at a tilt (using the tilt sensor), immediately store the tilt sensor output, and use this value as the reference for monitoring both short-term and long-term changes.

We recommend to monitor long-term changes of the sensor tilt, and generate a warning in case of changes  $> 1^\circ$  from the stored value.

We recommend to check the sensor temperature against the dewpoint or ambient temperature. The sensor temperature should always be higher than ambient temperature and dewpoint.

We recommend to monitor internal humidity trends on a yearly scale, using nighttime values only, and generate a warning if the relative humidity is consistently  $> 50\%$  at body temperatures  $< 20^\circ\text{C}$ .

We recommend to monitor ventilator speed and generate a warning if the speed is below 5000 RPM.

We recommend to monitor heater current and generate a warning if the current is below 0.25 A.

### 5.2 Sensor temperature

SR30-D1's low temperature dependence makes it an ideal candidate for use under very cold and very hot conditions. Measurement of the sensors temperature is done using a high accuracy digital sensor temperature sensor. The sensor signal serves to externally monitor the SR30-D1 temperature and, at the same time, is used by the internal electronics for temperature correction of the measurands. The temperature dependence of every individual instrument is tested and supplied on the product certificate as a second degree polynomial. Temperature correction of the irradiance signal is programmed into each sensor and is taken care of fully automatically by the internal electronics. The temperature measurement can also be used to check that the sensor remains above dewpoint.

### 5.3 Tilt angle

To allow remote monitoring of the instrument tilt and to assist in the tilted installation of the instrument, the SR30 features a digital tilt sensor. The tilt sensor measures the instrument angle on three axes and calculates the corresponding zenith tilt angle internally. For an accurate absolute measurement of the tilt angle with respect to horizontal, the sensor is factory calibrated relative to the bubble level and using an independent tilt measurement. Temperature correction coefficients of the tilt measurement are programmed during production and provided for each individual sensor on the product certificate. The tilt sensor has an absolute accuracy of  $\pm 1^\circ$  between  $0^\circ$  and  $90^\circ$  tilt angle. This accuracy is sufficient for use in PV performance monitoring and installation in plane of array.

### 5.4 Internal relative humidity

When SR30-D1 accumulates too much moisture, the internals of the sensor will get damaged. Therefore, it is advised to take regular measurements of the internal relative humidity of the sensor. These measurement are made available in the "humidity" register. We recommend to take regular measurements of the internal humidity of the sensor. The long-term (yearly) trend in relative humidity will show the slow saturation of the internal desiccant. The desiccant replacement interval is  $> 5$  years. The relative humidity levels in the sensor depend both on the absolute temperature and the desiccant. The desiccant releases absorbed water as a function of temperature and saturation level. Because of these effects, the short-term relative humidity measurement is not a good indicator of the desiccant condition. The relative humidity levels are preferably measured at low temperatures; we recommend to store measurements taken around midnight (24:00 local time) and monitor changes on a yearly basis. The combined accuracy of the relative humidity sensor is approximately 5 % of the reading.

### 5.5 Heater current

The heater current measurement is an indicative, unverified measurement. Using the heater current reading, an estimation of the heater power can be made. Because the voltage across the heating element is 5.0 Volt, the heater power is given by:

$$P_{\text{heater}} [\text{W}] = 5.0 [\text{V}] \times \text{"heater current"} [\text{A}]$$

Please note that even though the power delivered by the heater is the largest contributor, also the ventilator and the electronic circuitry contribute to heating of the sensor.

## **5.6 Ventilator current**

The rotation speed of the ventilator can vary significantly with temperature. This variation will also be reflected in the ventilator current. Apart from this, the ventilator current measurement is an unverified measurement. For these reasons the ventilator current reading should only be used as a binary [ON]/[OFF] indicator, solely to determine the actual ventilator state independently.

## **5.7 Ventilator speed**

The fan speed gives the actual rotation frequency of the fan in RPM, irrespective of whether it is switched on or off. The nominal ventilator speed is 7400 RPM at 20 °C. Depending on operating conditions the speed may vary. Especially at temperatures below -10 °C ventilator speed may be significantly lower. When the speed lies consistently below 5000 RPM, maintenance is required, and replacement of the ventilator may be needed.

## 6 Installation of SR30-D1

### 6.1 Site selection and installation

**Table 6.1.1** Recommendations for installation of pyranometers (continued on next page)

Location	the horizon should be as free from obstacles as possible. Ideally, there should be no objects between the course of the sun and the instrument.
Mechanical mounting / thermal insulation	preferably, use the optional spring-loaded levelling mount for mounting to a flat surface, or use the optional tube mount.  if not, use connection by bolts to the bottom plate of the instrument. A pyranometer is sensitive to thermal shocks. Do not mount the instrument with the body in direct thermal contact to the mounting plate (so always use the levelling feet also if the mounting is not horizontal), do not mount the instrument on objects that become very hot (black coated metal plates).
Instrument mounting with 2 bolts (without optional levelling mount)	2 x M5 bolt at $46 \times 10^{-3}$ m centre to centre distance on north-south axis, connection from below under the bottom plate of the instrument.
Instrument mounting with one bolt (without optional levelling mount)	1 x M6 bolt at the centre of the instrument, connection from below under the bottom plate of the instrument.
Performing a representative measurement	the pyranometer measures the solar radiation in the plane of the sensor. Some installations require a tilted or inverted position. The sensor bottom plate, parallel to the black sensor surface, should be mounted parallel to the plane of interest. in case a pyranometer is not mounted horizontally or in case the horizon is obstructed, the representativeness of the location becomes an important element of the measurement. See the chapter on uncertainty evaluation.
Levelling	in case of horizontal mounting, use the bubble level and levelling feet. after levelling horizontally (using the bubble level) immediately store the tilt sensor output, and use this value as the reference for monitoring both short-term and long-term changes.



**Table 6.1.1** Recommendations for installation of pyranometers (started on previous page)

Tilted installation	for tilted installation, the tilt sensor provides a sufficiently accurate measurement. The register "tilt angle" can be used when mounting and levelling the sensor.
Instrument orientation	by convention: with the cable exit pointing to the nearest pole, so the cable exit should point north in the northern hemisphere, south in the southern hemisphere.
Installation height	in case of inverted installation, WMO recommends a distance of 1.5 m between soil surface and sensor (reducing the effect of shadows and in order to obtain good spatial averaging).

## 6.2 Installation of the sun screen

SR30-D1's bubble level can be inspected at all times, even with the sun screen installed: a small window allows to see the bubble level. The quick release system of SR30-D1's sun screen allows for easy and secure mounting of the sun screen on the sensor. Installation and removal of the the connector can be done after removal of the sun screen.

The quick release system consists of a spring loaded lever opposite the bubble level window of the SR30-D1 sun screen. The bottom of the handle can be pulled out gently. Once the handle is pulled out and fully released, as shown in the figure below, the sun screen can be lifted off manually for removal. Installing the sun screen is easy too: pull out the bottom of the quick release system handle so it is fully released, place the screen on SR30-D1 and, once it is positioned properly, press the handle of the quick release system until it is locked.



**Figure 6.2.1** SR30-D1's sun screen with its quick release system and bubble level window



**Figure 6.2.2** *Installation of SR30-D1's sun screen*

### **6.3 Installation of optional mounts**

#### **6.3.1 Levelling mount**

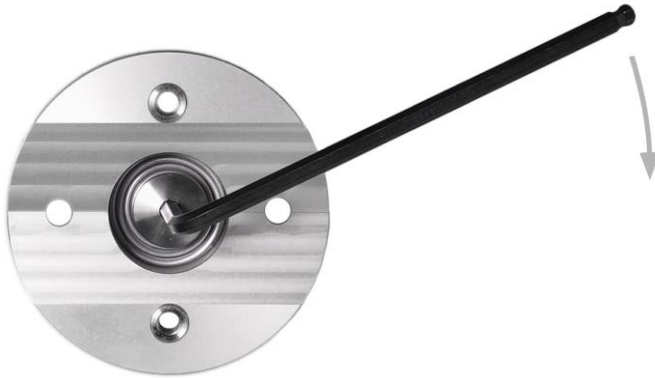
The optional levelling mount, for simplified mounting and levelling of SR30-D1 on a flat surface such as a platform or bracket, is easy to use. It can be fitted to SR30-D1 using the mount's spring-loaded centre bolt and a 4 mm hex key or a 10 mm spanner. It can be mounted on a flat surface by inserting two M5 bolts (not included) in the designated holes.



**Figure 6.3.1.1** *Optional spring-loaded levelling mount for SR30-D1*

The preferred way to connect the mount to SR30-D1 and lock its connection, is by using a 4 mm hex key via the bottom part of the levelling mount (see Figure 6.3.1.2). If the bottom part is not accessible, the connection between SR30-D1 and the mount can be made by using a 10 mm spanner (see Figure 6.3.1.3). The spanner may be used as well

to lock, or unlock, when SR30-D1 is already fitted to the mount (See Figure 6.3.1.4). In all cases, ensure the legs of SR30-D1 fit into one of the small ledges of the levelling mount. Locking is in place, when the nut of the spring-loaded centre bolt is turned all the way towards SR30-D1's bottom panel.



**Figure 6.3.1.2** bottom of SR30-D1 levelling mount. Preferred (un)locking with 4 mm hex key



**Figure 6.3.1.3** SR30-D1 levelling mount seen from above: (un)locking with a 10 mm spanner



**Figure 6.3.1.4** SR30-D1 levelling mount seen from the side: (un)locking with a 10 mm spanner

The levelling mount is spring-loaded. Once SR30-D1 is connected and locked to the levelling mount, SR30-D1 can be levelled by the user, judging the bubble level. Levelling is done by fastening or loosening SR30-D1's two adjustable levelling feet by hand. SR30-D1's static foot remains fixed. Fasten or loosen both legs so that the instrument is level, judging by the bubble level.



**Figure 6.3.1.5** SR30-D1 locked on its optional levelling mount: by fastening (on the left) or loosening (on the right) SR30-D1's two adjustable feet, SR30-D1 can be levelled, judging by the bubble level. SR30-D1's static foot remains fixed. In all cases, ensure the legs of SR30-D1 fit into one of the small ledges of the levelling mount. Locking is in place, when the nut is turned all the way against the bottom plate of SR30-D1

### 6.3.2 Tube levelling mount

SR30-D1 may also be mounted on a tube or a mounting rod using SR30-D1's optional tube mount.



**Figure 6.3.2.1** SR30-D1 mounted with its optional tube levelling mount on a tube

The tube mount option includes the levelling mount, described in the previous paragraph, a lower clamp for tube mounting and two sets of bolts for tube diameters 25 to 40 mm (tube not included). Installation requires a 4 mm hex key.



**Figure 6.3.2.2** *Optional tube levelling mount; installation requires a 4 mm hex key*

#### **6.4 Installation of optional extension cable of 20 m**



**Figure 6.4.1** *Optional extension cable of 20 metres with 2 connectors*

Extension to longer cable lengths is achieved by adding extension cables of 20 m with 2 connectors, male and female M12-A.

## 6.5 Electrical connection of SR30-D1: wiring diagram

The instrument must be powered by an external power supply, providing an operating voltage in the range from 8 to 30 VDC. This is the main power supply for the sensor, using the brown and black wires. Do not put more than 30 Volt across these wires, this will damage the sensor.



This manual supports model SR30-D1, the predecessor of SR30-M2-D1. Need support for the new SR30-M2-D1? Please refer to its separate user manual.



When SR30-D1 is installed using the recommended SR30-M2-D1 wiring scheme, SR30-D1 RS-485 communication will NOT function reliably.

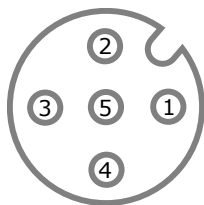


When SR30-M2-D1 is installed using the recommended SR30-D1 wiring scheme, users will NOT benefit from improved signal integrity.

**Table 6.5.1** *Wiring diagram of SR30-D1*

PIN	WIRE	SR30-D1 Modbus over RS-485
1	Brown	VDC [+]
4	Black	VDC [-]
3	Blue	not connected
2	White	RS-485 B / B' [+]
5	Grey	RS-485 A / A' [-]
	Yellow	shield

Note 2: at the connector-end of the cable, the shield is connected to the connector housing



**Figure 6.5.1:** *Connector layout of SR30-D1 indicating PIN numbers (viewed from cable side)*

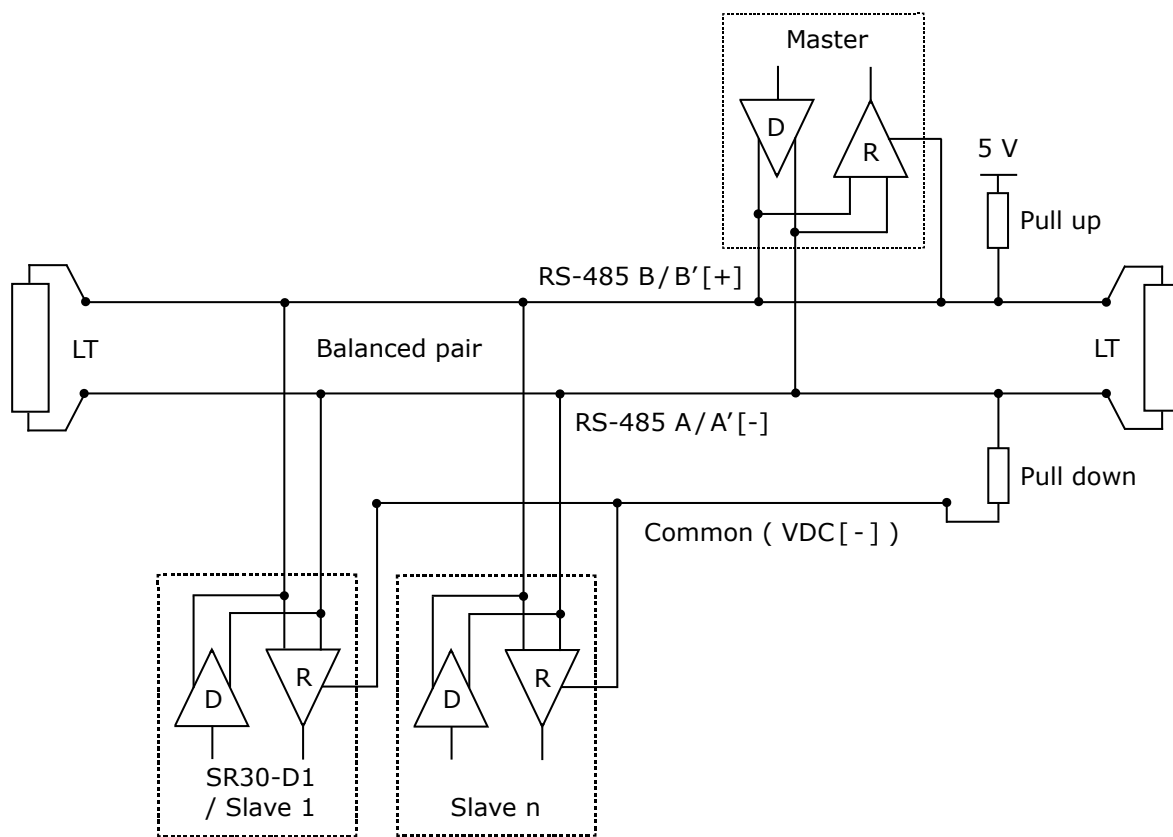
## 6.6 Grounding and use of the shield

Grounding and shield use are the responsibility of the user. The cable shield (called shield in the wiring diagram) is connected to the aluminium instrument body via the connector. In most situations, the instrument will be screwed on a mounting platform that is locally grounded. In these cases the shield at the cable end should not be connected at all. When a ground connection is not obtained through the instrument body, for instance in

laboratory experiments, the shield should be connected to the local ground at the cable end. This is typically the ground or low voltage of the power supply or the common of the network. In exceptional cases, for instance when both the instrument and a datalogger are connected to a small size mast, the local ground at the mounting platform is the same as the network ground. In such cases ground connection may be made both to the instrument body and to the shield at the cable end.

## 6.7 Connecting to an RS-485 network

SR30-D1 is designed for a two-wire (half-duplex) RS-485 network. In such a network, SR30-D1 acts as a slave, receiving data requests from the master. An example of the topology of an RS-485 two-wire network is shown in the figure below. SR30-D1 is powered from 8 to 30 VDC. The power supply is not shown in the figure. The VDC [-] power supply ground must be connected to the common line of the network.



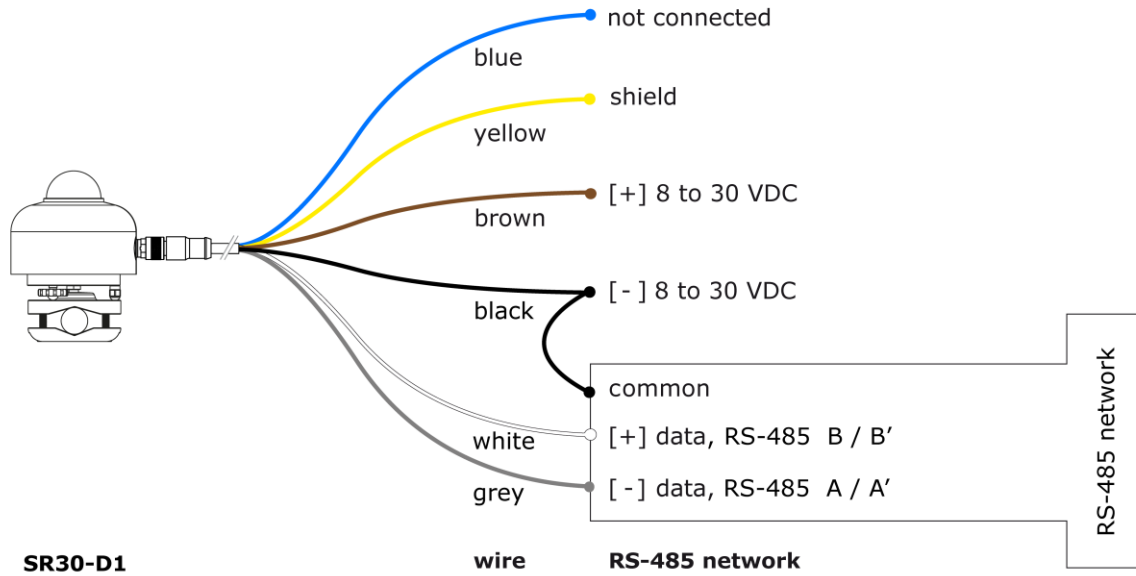
**Figure 6.7.1** Typical topology of a two-wire RS-485 network, figure adapted from: *Modbus over serial line specification and implementation guide V1.02 (www.modbus.org)*. The power supply is not shown in this figure.

After the last nodes in the network, on both sides, line termination resistors (LT) are required to eliminate reflections in the network. According to the EIA/TIA-485 standard, these LT have a typical value of 120 to 150  $\Omega$ . Never place more than two LT on the network and never place the LT on a derivation cable. To minimise noise on the network

when no transmission is occurring, a pull up and pull down resistor are required. Typical values for both resistors are in the range from 650 to 850  $\Omega$ .



This manual supports model SR30-D1, the predecessor of SR30-M2-D1. Need support for the new SR30-M2-D1? Please refer to its separate user manual.



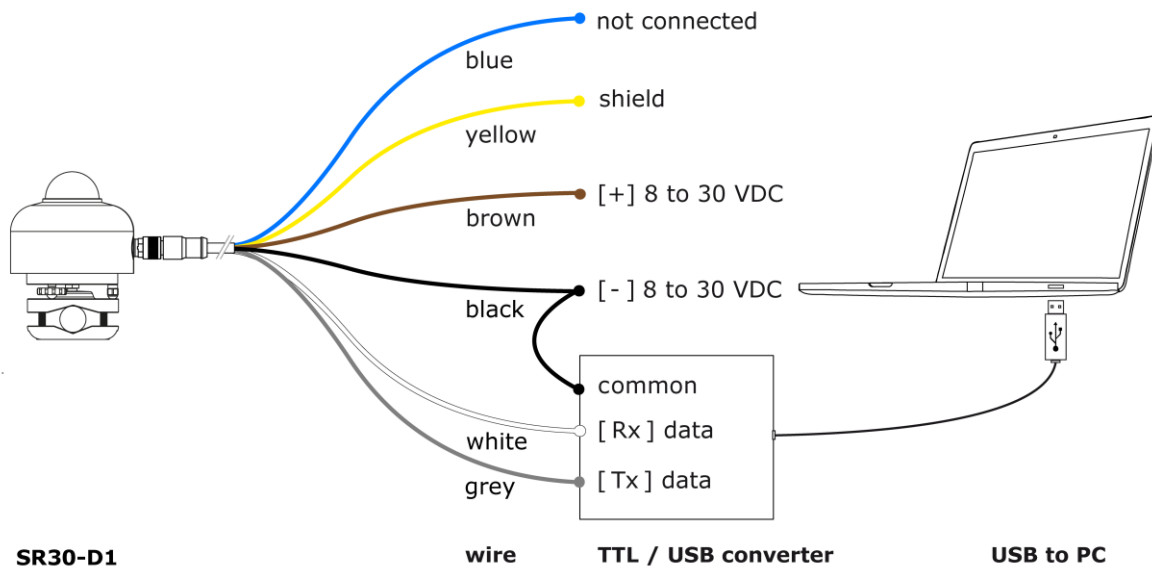
**Figure 6.7.2** Connection of SR30-D1 to an RS-485 network. SR30-D1 is powered by an external power supply of 8 to 30 VDC.



## 6.8 Connecting to a PC

SR30-D1 can be accessed via a PC. In that case communication with the sensor is done via the user interface offered by the Sensor Manager software (see the next chapters) or by another Modbus testing tool.

Depending on the available ports on the PC, either an RS-485 to USB converter or an RS-485 to RS-232 converter is used. The figure below shows how connections are made. The converter must have galvanic isolation between signal input and output to prevent static electricity or other high-voltage surges to enter the data lines. An external power supply is required to power the SR30-D1 (8 to 30 VDC). An RS-485 to USB converter is usually powered via the USB interface: in this case no external power is needed to feed the converter. If an RS-485 to RS-232 converter is used, this converter should be powered by an external source. This may be the same supply used for the SR30-D1.



**Figure 6.8.1** Connecting SR30-D1 to an RS-485 to USB converter and a PC

## 7 Communication with SR30-D1

### 7.1 PC communication: Sensor Manager software

SR30-D1 can be accessed via a PC. In that case the communication with the sensor is done via the user interface offered by the Hukseflux Sensor Manager software or by another Modbus testing tool. The Sensor Manager can be downloaded free of charge via <https://www.hukseflux.com/downloads>. There are links to testing tools, paid or freeware, available at [www.modbus.org](http://www.modbus.org).

The Hukseflux Sensor Manager software provides a user interface for communication between a PC and SR30-D1. It allows the user to locate, configure and test one or more SR30-D1's and to perform simple laboratory measurements using a PC. The Sensor Manager's most common use is for initial functionality testing and modification of the SR30-D1 Modbus address and communication settings. It is not intended for long-term continuous measurement purposes.

The latest version of the Hukseflux Sensor Manager software, version v2021 or higher, is downloadable via <https://www.hukseflux.com/downloads>. Please always use the latest software version. For support of the Sensor Manager software, visit the [Sensor Manager's online support page](#), which includes a dedicated user manual for installing and using the software.

### 7.2 Network communication: function codes, registers, coils

*Warning: Using the same Modbus address for more than one device will lead to irregular behaviour of the entire network.* This chapter describes function codes, data model and registers used in the SR30-D1 firmware. Communication is organised according to the specifications provided by the Modbus Organization. These specifications are explained in the documents "Modbus application protocol v1.1b" and "Modbus over serial line v1.02". These documents can be acquired free of charge at [www.modbus.org](http://www.modbus.org).

**Table 7.2.1** Supported Modbus function codes

SUPPORTED MODBUS FUNCTION CODES	
FUNCTION CODE (HEX)	DESCRIPTION
0x01	Read Coils
0x02	Read Discrete Inputs
0x03	Read Holding Registers
0x04	Read Input Register
0x05	Write Single Coil
0x06	Write Single Holding Register
0x0F	Write Multiple Coils
0x10	Write Multiple Registers

**Table 7.2.2** *Modbus data model*

MODBUS DATA MODEL		
PRIMARY TABLES	OBJECT TYPE	TYPE OF
Discrete input	Single bit	R
Coil	Single bit	R/W
Input register	16 bit word	R
Holding register	16 bit word	R/W

R = read only, W = write only, R/W = read / write

The instrument does not distinguish between *discrete input* and *coil*; neither between *input register* and *holding register*.

**Table 7.2.3** *Format of data*

FORMAT OF DATA	DESCRIPTION
U16	Unsigned 16 bit integer
S16	Signed 16 bit integer
U32	Unsigned 32 bit integer
S32	Signed 32 bit integer
Float	IEEE 754 32 bit floating point format
String	A string of ASCII characters

The data format includes *signed* and *unsigned* integers. The difference between these types is that a *signed* integer passes on negative values, which reduces the range of the integer by half. Up to five 16 bit registers can be requested in one request; if requesting six or more registers, multiple requests should be used.

If the format of data is a signed or an unsigned 32 bit integer, the first register received is the most significant word (MSW) and the second register is the least significant word (LSW). This way two 16 bit registers are reserved for a 32 bit integer. If the format of data is *float*, it is a 32 bit floating point operator and two 16 bit registers are reserved as well. Most network managing programs have standard menus performing this type of conversion. In case manual conversion is required, see the appendix on conversion of a floating point number to a decimal number. MSW and LSW should be read together in one request. This is necessary to make sure both registers contain the data of one internal voltage measurement. Reading out the registers with two different instructions may lead to the combination of LSW and MSW of two measurements at different points in time.

An Unsigned 32 bit integer can be calculated by the formula:  $(MSW \times 2^{16}) + LSW = U32$ . An example of such a calculation is available in the paragraph "Network communication: example master request to SR30-D1".



Your data request may need an offset of +1 for each SR30-D1 register number, depending on processing by the network master. Example: SR30-D1 register number 7 + master offset = 7 + 1 = master register number 8. Consult the manual of the device acting as the local master.

**Table 7.2.4** *Modbus registers 0 to 31, measurements. For basic operation, Hukseflux recommends to read out registers 2 + 3 for solar radiation, register 6 for instrument body temperature and register 40 for the sensor serial number.*

MODBUS REGISTERS 0-31				
REGISTER NUMBER	PARAMETER	DESCRIPTION OF CONTENT	TYPE OF	FORMAT OF DATA
0	Modbus address	Sensor address in Modbus network, default = 1	R/W	U16
1	Serial communication settings	Sets the serial communication, default = 5	R/W	U16
2 + 3	Irradiance (temperature compensated signal)	Temperature compensated signal in $\times 0.01 \text{ W/m}^2$	R	S32
4 + 5	Irradiance (uncompensated signal)	Uncompensated signal in $\times 0.01 \text{ W/m}^2$	R	S32
6	Sensor body temperature	In $\times 0.01 \text{ }^\circ\text{C}$	R	S16
7	Sensor electrical resistance	In $\times 0.1 \text{ } \Omega$	R	U16
8	Scaling factor irradiance	Default = 100	R	U16
9	Scaling factor temperature	Default = 100	R	U16
10 + 11	Sensor voltage output	In $\times 10^{-9} \text{ V}$	R	S32
12 to 31	Factory use only			

Register 0, *Modbus address*, contains the Modbus address of the sensor. This allows the Modbus master to detect the slave, SR30-D1, in its network. The address can be changed; the value of the address must be between 1 and 247. The default Modbus address is 1.

Note: The sensor needs to be restarted before this change becomes effective.

Register 1, *Serial communication settings*, is used to enter the settings for baud rate and the framing of the serial data transfer. Default setting is setting number 5: *19200 baud, 8 data bits, even parity and 1 stop bit*. Setting options are shown in the table below.

Note: The sensor needs to be restarted before this change becomes effective.

**Table 7.2.5** *Setting options of register 1*

SETTING OPTIONS				
SETTING NUMBER	BAUD RATE	DATABITS	STOPBITS	PARITY
1	9600	8	1	none
2	9600	8	1	even
3	9600	8	1	odd
4	19200	8	1	none
5 (= default)	19200	8	1	even
6	19200	8	1	odd
7	38400	8	1	none
8	38400	8	1	even
9	38400	8	1	odd
10	115200	8	1	none
11	115200	8	1	even
12	115200	8	1	odd

Register 2 + 3, *Irradiance (temperature compensated signal)*, provides the temperature compensated solar radiation output in 0.01 W/m<sup>2</sup>. The value given must be divided by 100 to get the value in W/m<sup>2</sup>. Hukseflux recommends using this data to achieve the highest accuracy. MSW and LSW should be read together in one request.

Register 4 + 5, *Irradiance (uncompensated signal)*. *Use for comparison purposes only.* Provides the sensor output in 0.01 W/m<sup>2</sup>, not compensated for temperature dependence. The data must be divided by 100 to get the value in W/m<sup>2</sup>. Hukseflux recommends not to use this data. MSW and LSW should be read together in one request.

Register 6, *Instrument body temperature*, provides the temperature of the instrument body in 0.01 °C. The data must be divided by 100 to achieve the value in °C.

Register 7, *Sensor electrical resistance*, sensor resistance in 0.1 Ω. The data needs to be divided by 10 to get the value in Ω. This register returns a 0 by default. To read the resistance, first a measurement has to be performed. This can be done by writing 0xFF00 to coil 2. Hukseflux recommends to use this function only when necessary for diagnostics in case of sensor failure.

Register 8, *Scaling factor irradiance*, default scaling factor is 100.

Register 9, *Scaling factor temperature*, default scaling factor is 100.

Register 10 + 11, *Sensor voltage output*, sensor voltage output signal of the thermopile in  $\times 10^{-9}$  V.

**Table 7.2.6** Modbus registers 32 to 62, sensor and calibration information

MODBUS REGISTERS 32-62				
REGISTER NUMBER	PARAMETER	DESCRIPTION OF CONTENT	TYPE OF	FORMAT OF DATA
32 to 35	Sensor model	Part one of sensor description	R	String
36 to 39	Sensor model	Part two of sensor description	R	String
40	Sensor serial number		R	U16
41 + 42	Sensor sensitivity	In $\times 10^{-6} \text{ V}/(\text{W}/\text{m}^2)$	R	Float
43	Response time	In $\times 0.1 \text{ s}$	R	U16
44	Sensor resistance	In $\times 0.1 \Omega$	R	U16
45	Reserved	Always 0	R	U16
46 + 47	Sensor calibration date	Calibration date of the sensor in YYYYMMDD	R	U32
48 to 60	Factory use			
61	Firmware version		R	U16
62	Hardware version		R	U16

Register 32 to 39, *Sensor model*, String of 8 registers. This register will return 8 numbers, which correspond with ASCII characters.

Register 40, Sensor serial number.

Register 41 + 42, *Sensor sensitivity*, the sensitivity of the sensor in  $\times 10^{-6} \text{ V}/(\text{W}/\text{m}^2)$ . Format of data is *float*.

Register 43, *Response time*, the response time of the sensor as measured in the factory in  $\times 0.1 \text{ s}$ . The value must be divided by 10 to get the value in s.

Register 44, *Sensor electrical resistance*, returns the electrical resistance measured during the sensor calibration. The resistance is in  $\times 0.1 \Omega$  and must be divided by 10 to get the value in  $\Omega$ .

Register 46 + 47, *Sensor calibration date*, last sensor calibration date, from which the sensitivity in register 41 and 42 was found, in YYYYMMDD.

Register 61, Firmware version.

Register 62, Hardware version.

**Table 7.2.7** Modbus registers 63 to 81, calibration history

<b>MODBUS REGISTERS 63-81</b>				
REGISTER NUMBER	PARAMETER	DESCRIPTION OF CONTENT	TYPE OF	FORMAT OF DATA
63 + 64	Sensor sensitivity history 1	In $\times 10^{-6}$ V/(W/m <sup>2</sup> ) Default value is 0	R	Float
65 + 66	Calibration date history 1	Former calibration date of the sensor in YYYYMMDD Default value is 0	R	U32
67 + 68	Sensor sensitivity history 2	See register 63 + 64	R	Float
69 + 70	Calibration date history 2	See register 65 + 66	R	U32
71 + 72	Sensor sensitivity history 3	See register 63 + 64	R	Float
73 + 74	Calibration date history 3	See register 65 + 66	R	U32
75 + 76	Sensor sensitivity history 4	See register 63 + 64	R	Float
77 + 78	Calibration date history 4	See register 65 + 66	R	U32
79 + 80	Sensor sensitivity history 5	See register 63 + 64	R	Float
81 + 82	Calibration date history 5	See register 65 + 66	R	U32

Register 63 to 82: Only accessible for writing by Sensor Manager *power users*: *power users* can write calibration history to registers 63 to 82. If default values are returned, no re-calibration has been written. Last calibration sensitivity and calibration date are available in register 41 + 42 and 46 + 47 respectively.

**Table 7.2.8** Modbus registers 83 to 85, directional response characterisation data

<b>MODBUS REGISTERS 83-85</b>				
REGISTER NUMBER	PARAMETER	DESCRIPTION OF CONTENT	TYPE OF	FORMAT OF DATA
83 + 84	Directional response measurement date	Directional response measurement date in YYYYMMDD	R	U32
85	Directional response measurement employee		R	U16

Register 83 to 85, these registers are for reference purposes.

**Table 7.2.9** Modbus registers 86 to 95, temperature response characterisation data

<b>MODBUS REGISTERS 86-95</b>				
REGISTER NUMBER	PARAMETER	DESCRIPTION OF CONTENT	TYPE OF	FORMAT OF DATA
86	Temperature response	In x 0.01 %	R	S16
87 + 88	Polynomial temperature coefficient a		R	Float
89 + 90	Polynomial temperature coefficient b		R	Float
91 + 92	Polynomial temperature coefficient c		R	Float
93 + 94	Temperature response characterisation measurement date	Temperature response characterisation measurement date of the sensor in YYYYMMDD.	R	U32
95	Temperature response characterisation measurement employee		R	U16

Register 86 to 95, these registers are for reference purposes.

**Table 7.2.10** Modbus registers 96 to 99, humidity sensor information

<b>MODBUS REGISTERS 96-99</b>				
REGISTER NUMBER	PARAMETER	DESCRIPTION OF CONTENT	TYPE OF	FORMAT OF DATA
96 + 97	Factory use			
98	Humidity (RH)	In x 0.01 %	R	U16
99	Humidity temperature	In x 0.01 °C	R	S16

Register 98, *Humidity*, provides the relative humidity within the instrument. The value must be divided by 100 to get the value in %.

Register 99, *Humidity temperature*, the temperature measured by the humidity sensor. The value must be divided by 100 to get the value in °C.



**Table 7.2.11** Modbus registers 137 to 140, pressure sensor information

<b>MODBUS REGISTERS 137-140</b>				
REGISTER NUMBER	PARAMETER	DESCRIPTION OF CONTENT	TYPE OF	FORMAT OF DATA
100-136	Factory use			
137	Pressure	In x (1/32) mbar	R	U16
138	Pressure average	In x (1/32) mbar	R	U16
139	Pressure temperature	In x (1/256) °C	R	S16
140	Pressure temperature average	In x (1/256) °C	R	S16

Register 137, *pressure*, provides the internal pressure of the sensor. The value must be divided by 32 to get the value in mbar.

Register 138, *pressure average*, provides the average internal pressure of the sensor. The value must be divided by 32 to get the value in mbar.

Register 139, *pressure temperature*, provides the temperature of the pressure sensor. The value must be divided by 256 to get the value in °C.

Register 140, *pressure temperature average*, provides the average temperature of the pressure sensor. The value must be divided by 256 to get the value in °C.

**Table 7.2.12** Modbus registers 141 to 199, tilt sensor information

<b>MODBUS REGISTERS 141-199</b>				
REGISTER NUMBER	PARAMETER	DESCRIPTION OF CONTENT	TYPE OF	FORMAT OF DATA
141 - 193	Factory use			
194	Tilt angle	In x 0.01 °	R	U16
195	Tilt angle average	In x 0.01 °	R	U16
196	Fan speed RPM	In x 1 RPM	R	U16
197	Factory use			
198	Heater current	In x 1 mA	R	U16
199	Fan current	In x 1 mA	R	U16

Register 194, *Tilt angle*, provides the angle in ° of the Z axis in comparison to the XY plane. In other words, *Tilt angle*, provides the instrument tilt angle in ° relative to horizontal. The value must be divided by 100 to get the value in °.

Register 195, *Tilt angle average*, provides the average angle of the Z axis in comparison to the XY plane. In other words, *Tilt angle average*, provides the average instrument tilt angle in ° relative to horizontal. The value must be divided by 100 to get the value in °.

Register 196, *Fan speed RPM*, provides the rotations per minute (RPM) of the fan.

Register 198, *Heater current*, provides the current draw of the heater in mA.

Register 199, *Fan current*, provides the current draw of the fan in mA.



Please note that if your data request needs an offset of +1 for each SR30-D1 register number, depending on processing by the network master, this offset applies to coils as well. Consult the manual of the device acting as the local master.

**Table 7.2.13** *Coils*

COILS				
COIL	PARAMETER	DESCRIPTION	TYPE OF	OBJECT TYPE
0	Restart	Restart the sensor	W	Single bit
1	Heater	Turn heater on/off	W	Single bit
2	Check	Measure sensor electrical resistance	W	Single bit
3	Fan	Turn fan on/off	W	Single bit

Coil 0, *Restart*, when 0xFF00 is written to this coil the sensor will restart. If applied, a new Modbus address or new serial settings will become effective.

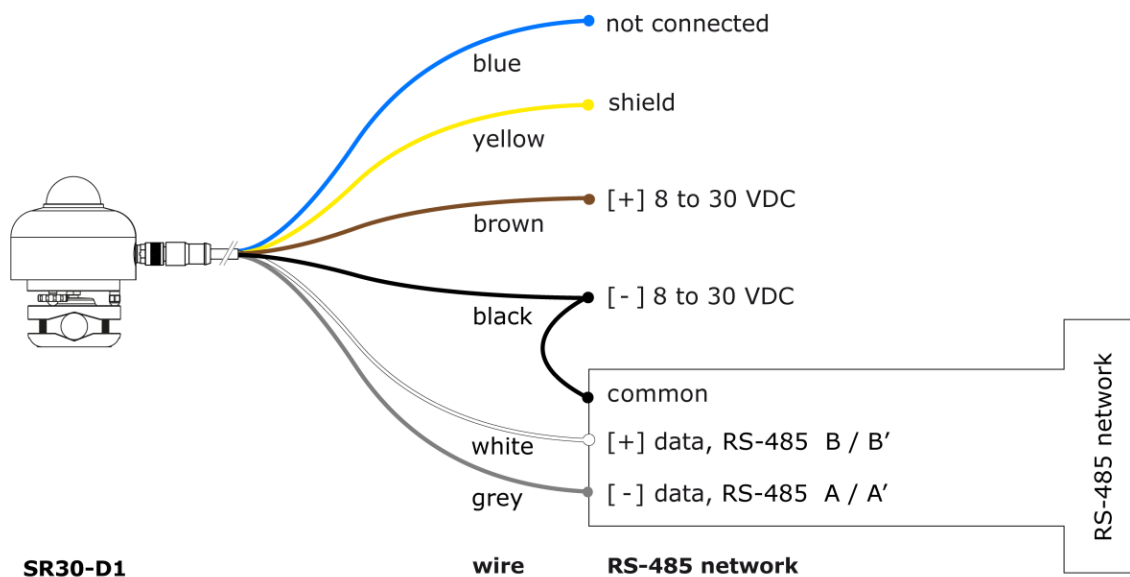
Coil 1, *Heater*, when 0xFF00 is written to this coil the heater will turn on. If 0x0000 is written the heater will turn off. Note: When active, the heater will be switched off for 5 seconds when the fan is turned on.

Coil 2, *Check*, when 0xFF00 is written to this coil the internal electronics will measure the electrical resistance of the thermopile. After the measurement, a new value will be written into register 7. Requesting to write this coil with a high repetition rate will result in irregular behaviour of the sensor; the check must be executed as an exceptional diagnostics routine only.

Coil 3, *Fan*, when 0xFF00 is written to this coil the fan will turn on. If 0x0000 is written, the fan will turn off.

### 7.3 Network communication: getting started

Once it has the correct Modbus address and communication settings, SR30-D1 can be connected directly to an RS-485 network and a power supply. How to physically connect a sensor as a slave in a Modbus network is shown in the figure below. In such a connection, the sensor is powered via an external power supply of 8 to 30 VDC. When the sensor is screwed onto a grounded mounting plate, which is usually the case, the shield is not connected to ground at the cable end.



**Figure 7.3.1** Connecting SR30-D1 to a typical RS-485 network

Installing an SR30-D1 in the network also requires configuring the communication for this new Modbus device. This usually consists of defining a request that can be broadcast by the master. If the SR30-D1 is not already defined as a standard sensor type on the network, contact the supplier of the network equipment to see if a library file for the SR30-D1 is available.

Typical operation requires the master to make a request of irradiance data in registers 2 + 3, sensor temperature in register 6, and the sensor serial number in register 40 every 1 second, and store the 60 second averages. The data format of register 2 + 3 is a signed 32 bit integer and the temperature in register 6 is a signed 16 bit integer.

Up to five 16 bit registers can be requested in one request. In case six or more registers are requested in just one request, SR30-D1 will not respond. If requesting six or more registers, multiple requests should be used: SR30-D1 will respond as expected.

### 7.3.1 Adapting the Modbus address and communication settings

Setting the instrument address and baud rate can be done in different ways:

- by connecting the sensor to the PC and using the Sensor Manager;
- by connecting the sensor to the PC and using another Modbus testing tool. There are links to different solutions available at [www.modbus.org](http://www.modbus.org);
- by using the available network user interface software.

The Modbus address is stored in register 0 and has a default value of 1. A user may change the address to a value in the range of 1 to 247. The address value must be unique in the network. The communication settings are stored in register 1. The default setting is setting number 5 representing a communication with 19200 baud, even parity bit, 8 data bits and 1 stop bit. After a new address or communication setting is written the sensor must be restarted. This can be done by writing 0xFF00 to coil 0.

## 7.4 Network communication: example master request to SR30-D1

Normal sensor operation consists of requesting the output of registers 2 + 3; the temperature compensated solar radiation. For quality assurance also the sensor serial number, register 40 and the temperature in register 6, are useful.

In this example an SR30-D1 has address 64. The example requests the solar radiation (temperature compensated) register 2 + 3, sensor serial number, register 40, and the temperature of the instrument register 6. The values are represented in hexadecimals.

Note: 32 bit data are represented in 2 registers. MSW and LSW should be read together in one request.

Request for solar radiation, register 2 + 3:

Master Request:

[40] [03] [00][00] [00][04] [4B][18]

[40] = Modbus slave address, decimal equivalent = 64

[03] = Modbus function; 03 Read holding registers

[00][00] = Starting register, the master requests data starting from register 0.

[00][04] = Length, the number of registers the master wants to read. 4 registers

[4B][18] = CRC, the checksum of the transmitted data

Sensor response:

[40] [03] [08] [00][40] [00][05] [00][01] [7C][4F] [79][DA]

[40] = Modbus slave address, decimal equivalent = 64

[03] = Modbus function

[08] = Number of bytes returned by the sensor. 8 bytes transmitted by the sensor

[00][40] = Register 0; Modbus address

[00][05] = Register 1; Serial settings, 19200 baud, 8 data bits, even parity bit, 1 stop bit  
 [00][01] = Register 2; Temperature compensated signal, Most Significant Word (MSW).  
 Decimal equivalent = 1  
 [7C][4F] = Register 3; Temperature compensated signal, Least Significant Word (LSW) =  
 Decimal equivalent = 31823  
 [79][DA] = CRC, the checksum of the transmitted data

Together, register 2 and 3 are representing the temperature compensated solar radiation output measured by the SR30-D1. The MSW is in register 2 and the LSW in 3. The output has to be calculated by the formula:  $((MSW \times 2^{16}) + LSW)/100$ . In this example the result is:  $((2^{16} \times 1) + 31823)/100 = 973.59 \text{ W/m}^2$

Request for body temperature, register 6:

Master Request:

[40][03][00][06][00][01][6B][1A]

[40] = Modbus Slave address  
 [03] = Modbus function  
 [00][06] = Start register  
 [00][01] = Number of registers  
 [6B][1A] = CRC

Sensor response:

[40][03][02][08][B1][43][FF]

[40] = Modbus Slave address  
 [03] = Modbus function  
 [02] = Number of bytes  
 [08][B1] = Content of register 7, decimal equivalent = 2225  
 [43][FF] = CRC

Temperature = Register 7 x 0.01 = 2225 x 0.01 = 22.25 °C

Register 6 represents the sensors body temperature. The received data needs to be divided by 100 to represent the correct outcome. In this example the result is: 2225 x 0.01 = 22.25 °C

Request for serial number, register 40:

Master Request:

[40][03][00][28][00][01][0B][13]

[40] = Modbus slave address  
 [03] = Modbus function  
 [00][28] = Start register

[00][01] = Number of registers  
[0B][13] = CRC

Sensor response:

[40][03][02][0A][29][43][35]

[40] = Modbus Slave address

[03] = Modbus function

[02] = Number of bytes

[0A][29] = Content of register 40, decimal equivalent = 2601

[43][35] = CRC

Register 40 represents the sensors serial number. In this example the serial number is 2601.

## 8 Making a dependable measurement

### 8.1 The concept of dependability

A measurement with a pyranometer is called “dependable” if it is reliable, i.e. measuring within required uncertainty limits, for most of the time and if problems, once they occur, can be solved quickly.

The requirements for a measurement with a pyranometer may be expressed by the user as:

- required uncertainty of the measurement (see following paragraphs)
- requirements for maintenance and repairs (possibilities for maintenance and repair including effort to be made and processing time)
- a requirement to the expected instrument lifetime (until it is no longer feasible to repair)

It is important to realise that the uncertainty of the measurement is not only determined by the instrument but also by the way it is used.

See also ISO 9060 note 5. In case of pyranometers, the measurement uncertainty as obtained during outdoor measurements is a function of:

- the instrument class
- the calibration procedure / uncertainty
- the duration of instrument employment under natural sunlight (involving the instrument stability specification)
- the measurement conditions (such as tilting, ventilation, shading, instrument temperature)
- maintenance (mainly fouling)
- the environmental conditions\*

Therefore, ISO 9060 says, “statements about the overall measurement uncertainty under outdoor conditions can only be made on an individual basis, taking all these factors into account”.

\* defined at Hukseflux as all factors outside the instrument that are relevant to the measurement such as the cloud cover (presence or absence of direct radiation), sun position, the local horizon (which may be obstructed) or condition of the ground (when tilted). The environmental conditions also involve the question whether or not the measurement at the location of measurement is representative of the quantity that should be measured.

## 8.2 Reliability of the measurement

A measurement is reliable if it measures within required uncertainty limits for most of the time. We distinguish between two causes of unreliability of the measurement:

- related to the reliability of the pyranometer and its design, manufacturing, calibration (hardware reliability).
- related to the reliability of the measurement uncertainty (measurement reliability), which involves hardware reliability as well as condition of use.

Most of the hardware reliability is the responsibility of the instrument manufacturer. The reliability of the measurement however is a joint responsibility of instrument manufacturer and user. As a function of user requirements, taking into account measurement conditions and environmental conditions, the user will select an instrument of a certain class, and define maintenance support procedures.

In many situations there is a limit to a realistically attainable accuracy level. This is due to conditions that are beyond control once the measurement system is in place. Typical limiting conditions are:

- the measurement conditions, for instance when working at extreme temperatures when the instrument temperature is at the extreme limits of the rated temperature range.
- the environmental conditions, for instance when installed at a sub-optimal measurement location with obstacles in the path of the sun.
- other environmental conditions, for instance when assessing PV system performance and the system contains panels at different tilt angles, the pyranometer measurement may not be representative of irradiance received by the entire PV system.

The measurement reliability can be improved by maintenance support. Important aspects are:

- dome fouling by deposition of dust, dew, rain or snow. Fouling results in undefined measurement uncertainty (sensitivity and directional error are no longer defined). This should be solved by regular inspection and cleaning.
- sensor instability. Maximum expected sensor aging is specified per instrument as its non-stability in [% change / year]. In case the sensor is not recalibrated, the uncertainty of the sensitivity gradually will increase. This is solved by regular recalibration.
- moisture condensing under pyranometer domes resulting in a slow change of sensitivity (within specifications). This is solved by regular replacement of desiccant or by maintenance (drying the entire sensor) in case the sensor allows this. For non-serviceable sensors like most second class pyranometers, this may slowly develop into a defect. For first class and secondary standard models (for instance model SR11 first class pyranometer and SR30 digital secondary standard pyranometer) extra desiccant is available.



Another way to improve measurement reliability is to introduce redundant sensors.

- the use of redundant instruments allows remote checks of one instrument using the other as a reference, which leads to a higher measurement reliability.
- in PV system performance monitoring, in addition to instruments measuring in the plane of array, horizontally placed instruments are used for the measurement of global radiation. Global irradiance data enable the user to compare the local climate and system efficiency between different sites. These data can also be compared to measurements by local meteorological stations.

### **8.3 Speed of repair and maintenance**

Dependability is not only a matter of reliability but also involves the reaction to problems; if the processing time of service and repairs is short, this contributes to the dependability.

The main maintenance actions are:

- cleaning of dome
- replacement of desiccant
- replacement of cabling
- replacement of ventilator

For optimisation of dependability a user should:

- design a schedule of regular maintenance
- design a schedule of repair or replacement in case of defects

When operating multiple instruments in a network, Hukseflux recommends keeping procedures simple and having a few spare instruments to act as replacements during service, recalibrations and repair.

### **8.4 Uncertainty evaluation**

The uncertainty of a measurement under outdoor or indoor conditions depends on many factors, see paragraph 1 of this chapter. It is not possible to give one figure for pyranometer measurement uncertainty. The work on uncertainty evaluation is "in progress". There are several groups around the world participating in standardisation of the method of calculation. The effort aims to work according to the guidelines for uncertainty evaluation (according to the "Guide to Expression of Uncertainty in Measurement" or GUM).

#### 8.4.1 Evaluation of measurement uncertainty under outdoor conditions

Hukseflux actively participates in the discussions about pyranometer measurement uncertainty; we also provide spreadsheets, reflecting the latest state of the art, to assist our users in making their own evaluation. The input to the assessment is summarised:

- 1) The formal evaluation of uncertainty should be performed in accordance with ISO 98-3 Guide to the Expression of Uncertainty in Measurement, GUM.
- 2) The specifications of the instrument according to the list of ISO 9060 classification of pyranometers and pyrhemometers are entered as limiting values of possible errors, to be analysed as type B evaluation of standard uncertainty per paragraph 4.3.7. of GUM. A priori distributions are chosen as rectangular.
- 3) A separate estimate has to be entered to allow for estimated uncertainty due to the instrument maintenance level.
- 4) The calibration uncertainty has to be entered. Please note that Hukseflux calibration uncertainties are lower than those of alternative equipment. These uncertainties are entered in measurement equation (equation is usually Formula 0.1:  $E = U/S$ ), either as an uncertainty in E (zero offsets, directional response) in U (voltage readout errors) or in S (tilt error, temperature dependence, calibration uncertainty).
- 5) In uncertainty analysis for pyranometers, the location and date of interest is entered. The course of the sun is then calculated, and the direct and diffuse components are estimated, based on a model; the angle of incidence of direct radiation is a major factor in the uncertainty.
- 6) In uncertainty analysis for modern pyrhemometers: tilt angle dependence often is so low that one single typical observation may be sufficient.
- 7) In case of special measurement conditions, typical specification values are chosen. These should for instance account for the measurement conditions (shaded / unshaded, ventilated/ unventilated, horizontal / tilted) and environmental conditions (clear sky / cloudy, working temperature range).
- 8) Among the various sources of uncertainty, some are "correlated"; i.e. present during the entire measurement process, and not cancelling or converging to zero when averaged over time; the off-diagonal elements of the covariance matrix are not zero. Paragraph 5.2 of GUM.
- 9) Among the various sources of uncertainty, some are "uncorrelated"; cancelling or converging to zero when averaged over time; the off-diagonal elements of the covariance matrix are zero. Paragraph 5.1 of GUM.
- 10) Among the various sources of uncertainty, some are "not included in analysis"; this applies for instance to non-linearity for pyranometers, because it is already included in the directional error, and the spectral response for pyranometers and pyrhemometers because it is already taken into account in the calibration process.

**Table 8.4.1.1** Preliminary estimates of achievable uncertainties of measurements with Hukseflux pyranometers. The estimates are based on typical pyranometer properties and calibration uncertainty, for sunny, clear sky days and well maintained stations, without uncertainty loss due to lack of maintenance and due to instrument fouling. The table specifies expanded uncertainties with a coverage factor of 2 and confidence level of 95 %. Estimates are based on 1 s sampling. **IMPORTANT NOTE:** there is no international consensus on uncertainty evaluation of pyranometer measurements, so this table should not be used as a formal reference.

<b>Pyranometer class (ISO 9060)</b>	<b>season</b>	<b>latitude</b>	<b>uncertainty minute totals at solar noon</b>	<b>uncertainty hourly totals at solar noon</b>	<b>uncertainty daily totals</b>
secondary standard (SR30-D1)	summer	mid-latitude	2.7 %	2.0 %	1.9 %
		equator	2.6 %	1.9 %	1.7 %
		pole	7.9 %	5.6 %	4.5 %
	winter	mid-latitude	3.4 %	2.5 %	2.7 %
first class	summer	mid-latitude	4.7 %	3.3 %	3.4 %
		equator	4.4 %	3.1 %	2.9 %
		pole	16.1%	11.4 %	9.2 %
	winter	mid-latitude	6.5 %	4.5 %	5.2 %
second class	summer	mid-latitude	8.4 %	5.9 %	6.2 %
		equator	7.8 %	5.5 %	5.3 %
		pole	29.5 %	21.6 %	18.0 %
	winter	mid-latitude	11.4 %	8.1 %	9.9 %

#### 8.4.2 Calibration uncertainty

New calibration procedures were developed in close cooperation with PMOD World Radiation Center in Davos, Switzerland. The latest calibration method results in an uncertainty of the sensitivity of less than 1.2 %, compared to typical uncertainties of higher than 1.7 % for this pyranometer class. See the appendix for detailed information on calibration hierarchy.

## 9 Maintenance and trouble shooting

### 9.1 Recommended maintenance and quality assurance

SR30-D1 can measure reliably at a low level of maintenance in most locations. Usually unreliable measurements will be detected as unreasonably large or small measured values. As a general rule this means that regular visual inspection combined with a critical review of the measured data, preferably checking against other measurements, is the preferred way to obtain a reliable measurement.

**Table 9.1.1** *Recommended maintenance of SR30-D1. If possible the data analysis and cleaning (1 and 2) should be done on a daily basis. (continued on next page)*

<b>MINIMUM RECOMMENDED PYRANOMETER MAINTENANCE</b>			
	INTERVAL	SUBJECT	ACTION
1	1 week	data analysis	compare measured data to maximum possible / maximum expected irradiance and to other measurements nearby (redundant instruments). Also historical seasonal records can be used as a source for expected values. Analyse night time signals. These signals may be negative (down to - 5 W/m <sup>2</sup> on clear windless nights), due to zero offset a. In case of use with PV systems, compare daytime measurements to PV system output. Look for any patterns and events that deviate from what is normal or expected. check tilt, internal humidity, internal pressure, according to the recommendations in the chapter about remote diagnostics
2	2 weeks	cleaning	use a soft cloth to clean the dome of the instrument, persistent stains can be treated with soapy water or alcohol
3	6 months	inspection	inspect cable quality, inspect connectors, inspect mounting position, inspect cable, clean instrument, clean cable, inspect levelling, change instrument tilt angle in case this is out of specification, inspect mounting connection, inspect interior of dome for condensation
5	2 years	recalibration	recalibration by side-by-side comparison to a higher standard instrument in the field according to ISO 9847 request "power user" status and a password at the factory permitting to write to registers holding the sensitivity and the calibration history data via the Sensor Manager. Ask the manufacturer for directions. typically during calibration desiccant is replaced. Ask the manufacturer for directions
6		lifetime assessment	judge if the instrument should be reliable for another 2 years, or if it should be replaced

---

**MINIMUM RECOMMENDED PYRANOMETER MAINTENANCE (continued)**

---

INTERVAL	SUBJECT	ACTION
7 > 5 years	desiccant replacement	desiccant replacement. Ask the manufacturer for instructions
8	parts replacement	if applicable / necessary, replace the parts that are most exposed to ageing and weathering; cable, connector, sun screen, ventilator. NOTE: use Hukseflux approved parts only. ventilator replacement. Ask the manufacturer for instructions
9	internal inspection	if applicable: open instrument and inspect / replace O-rings;

---

## 9.2 Trouble shooting

**Table 9.2.1** *Trouble shooting for SR30-D1 (continued on next page)*

General	<p>Inspect the instrument for any damage.</p> <p>Inspect if the connector is properly attached.</p> <p>Check the condition of the connectors (on chassis as well as the cable).</p> <p>Inspect if the sensor receives DC voltage power in the range of 8 to 30 VDC.</p> <p>Inspect the connection of the shield (typically not connected at the network side).</p> <p>Inspect the connection of the sensor power supply, typically the negative is connected to the network <i>common</i>.</p> <p>Read out the internal humidity using the Modbus interface. If the reading is &gt; 50 % at 20 °C for at least 24 hours, the sensor may be leaking, or the desiccant may be saturated. If internal humidity is stored, look at the long-term trend. To investigate leakage, the user may also read out the internal pressure sensor and see if the internal pressure correlates with body temperature (this is a sign that the construction is closed) or not.</p> <p>Please contact the factory to discuss diagnostics and possible action.</p>
Prepare for indoor testing	<p>Install the Sensor Manager software on a PC. Equip the PC with RS-485 communication. Put DC voltage power to the sensor and establish communication with the sensor. At power-up the signal may have a temporary output level different from zero; an offset. Let this offset settle down.</p>
The sensor does not give any signal	<p>Check if the sensor reacts to light: expose the sensor to a strong light source, for instance a 100 W light bulb at 0.1 m distance. The signal should read &gt; 100 W/m<sup>2</sup> now. Darken the sensor either by putting something over it or switching off the light. The instrument voltage output should go down and within one minute approach 0 W/m<sup>2</sup>. Check the data acquisition by replacing the sensor with a spare sensor with the same address.</p>

---

Not able to communicate with the sensor	<p>Check all physical connections to the sensor and try connecting to the sensor again. If communicating is not possible, try to figure out if the address and communication settings are correct. Analyse the cable performance by measuring resistance from pins to cable ends. The electrical resistance should be <math>&lt; 10 \Omega</math>. In case of doubt, try a new cable.</p> <p>Connect sensor to a PC and perform the "Find" and "Find all" operation with the Sensor Manager to locate the sensor and verify the communication settings. If all physical connections are correct, and the sensor still cannot be found, please contact the factory to send the sensor to the manufacturer for diagnosis and service.</p>
SR30 does not respond to a request for 6 or more registers	<p>It is not possible to request more than five 16 bit registers in one request. In case of requesting six or more registers in just one request, the sensor will not respond. If requesting six or more registers, use multiple requests: the sensor will respond as expected.</p>
The sensor signal is unrealistically high or low	<p>Note that night-time signals may be negative (down to <math>-5 \text{ W/m}^2</math> on clear windless nights in standard operating mode), due to zero offset a.</p> <p>Check if the pyranometer has clean domes.</p> <p>Check the location of the pyranometer; are there any obstructions that could explain the measurement result.</p> <p>Check the orientation / levelling of the pyranometer.</p> <p>Check the cable condition looking for cable breaks. Check the condition of the connectors (on chassis as well as the cable).</p>
The sensor signal shows unexpected variations	<p>Check the presence of strong sources of electromagnetic radiation (radar, radio).</p> <p>Check the condition and connection of the shield.</p> <p>Check the condition of the sensor cable.</p> <p>Check if the cable is not moving during the measurement.</p> <p>Check the condition of the connectors (on chassis as well as the cable)</p>
The outer dome shows internal condensation	<p>In case there is a minor layer of moisture that is hardly visible: replace the desiccant and wait a few days to see if the situation improves. Ask the manufacturer for instructions.</p>
The inner dome shows internal condensation	<p>Arrange to send the sensor to the manufacturer for diagnosis and service.</p>

### 9.3 Calibration and checks in the field

Recalibration of field pyranometers is typically done by comparison in the field to a reference pyranometer. The applicable standard is ISO 9847 "International Standard- Solar Energy- calibration of field pyranometers by comparison to a reference pyranometer". At Hukseflux an indoor calibration according to the same standard is used.

Hukseflux recommendation for re-calibration:

if possible, perform calibration indoor by comparison to an identical reference instrument, under normal incidence conditions.

The recommended calibration interval of pyranometers is 2 years. The registers containing the applied sensitivity and the calibration history of SR30-D1 are accessible for users. This allows the user to choose his own local calibration service. The same feature may be used for remotely controlled re-calibration of pyranometers in the field. Ask Hukseflux for information on ISO and ASTM standardised procedures for field calibration. Request "power user" status and a password at the factory permitting to write to registers holding the sensitivity and the calibration history data via the Sensor Manager.

In case of field comparison; ISO recommends field calibration to a higher class pyranometer. Hukseflux suggests also allowing use of sensors of the same model and class, because intercomparisons of similar instruments have the advantage that they suffer from the same offsets. It is therefore just as good to compare to pyranometers of the same brand and type as to compare to an instrument of a higher class. ISO recommends to perform field calibration during several days; 2 to 3 days under cloudless conditions, 10 days under cloudy conditions. In general this is not achievable. In order to shorten the calibration process Hukseflux suggests to allow calibration at normal incidence, using hourly totals near solar noon.

Hukseflux main recommendations for field intercomparisons are:

- 1) to take normal incidence as a reference and not the entire day.
- 2) to take a reference of the same brand and type as the field pyranometer or a pyranometer of a higher class, and
- 3) to connect both to the same electronics, so that electronics errors (also offsets) are eliminated.
- 4) to mount all instruments on the same platform, so that they have the same body temperature.
- 5) assuming that the electronics are independently calibrated, to analyse radiation values at normal incidence radiation (possibly tilting the radiometers to approximately normal incidence), if this is not possible to compare 1 hour totals around solar noon for horizontally mounted instruments.
- 6) for second class radiometers, to correct deviations of more than  $\pm 10\%$ . Lower deviations should be interpreted as acceptable and should not lead to a revised sensitivity.

7) for first class pyranometers, to correct deviations of more than  $\pm 5\%$ . Lower deviations should be interpreted as acceptable and should not lead to a revised sensitivity.

8) for secondary standard instruments, to correct deviations of more than  $\pm 3\%$ . Lower deviations should be interpreted as acceptable and should not lead to a revised sensitivity.

## 9.4 Data quality assurance

Quality assurance can be done by:

- analysing trends in solar irradiance signal
- plotting the measured irradiance against mathematically generated expected values
- comparing irradiance measurements between sites
- analysis of night time signals

The main idea is that one should look out for any unrealistic values. There are programs on the market that can semi-automatically perform data screening. See for more information on such a program: [www.dqms.com](http://www.dqms.com).





## 10 Appendices



This manual supports model SR30-D1, the predecessor of SR30-M2-D1. Need support for the new SR30-M2-D1? Please refer to its separate user manual.

### **10.1 Appendix on cable extension / replacement**

The sensor cable of SR30-D1 is equipped with a M12-A straight connector. In case of cable replacement, it is recommended to purchase a new cable with connector at Hukseflux.

In case of cable extension, it is recommended to purchase an extension cable with connector pair at Hukseflux. Please note that Hukseflux does not provide support for Do-It-Yourself connector- and cable assembly.

SR30-D1 is equipped with one cable. Maximum length of the sensor cable depends on the RS-485 network topology applied in the field. In practice, daisy chain topologies or point to point (PtP) topologies are used. The length of the sensor cable should be as short as possible to avoid signal reflections on the line, in particular in daisy chain configurations.

In point to point configurations cable lengths can in theory be much longer; RS-485 is specified for cable lengths up to 1200 metres.

Connector, cable and cable connection specifications are summarised on the next page.

**Table 10.1.1** Preferred specifications for SR30-D1 cable replacement and extension

General replacement	please order a new cable with connector at Hukseflux
General cable extension	please order an extension cable with connector pair at Hukseflux
Connectors used	chassis: M12-A straight male connector, male thread, 5-pole manufacturer: Binder cable: M12-A straight female connector, female thread, 5-pole manufacturer: Binder the shield is electrically connected to the connector housing
Cable	5-wire, shielded manufacturer: Binder
Length	cables should be kept as short as possible, in particular in daisy chain topologies. In point to point topologies cable length should not exceed RS-485 specifications of maximum 1200 metres
Outer sheath	with specifications for outdoor use (for good stability in outdoor applications)

## 10.2 Appendix on tools for SR30-D1

**Table 10.2.1** Specifications of tools for SR30-D1

tooling required for sun screen fixation and removal	by hand
tooling required for opening of the sensor bottom	T10 torx key
tooling required for mounting and levelling SR30-D1 with the optional (tube) levelling mount	4 mm hex key and (alternatively) 10 mm spanner

### 10.3 Appendix on spare parts for SR30-D1

- levelling feet (set of 2)
- static foot
- sun screen for SR30-D1. Specify SCR05.
- ventilator for SR30-D1
- desiccant for SR30-D1 (silica gel, 2 x 1 g, in a HDPE bag)
- O-ring for SR30-D1
- cable for SR30-D1, with female M12-A connector at sensor end, pigtails of 0.15 m and conductors with ferrules (5, 10, 20 m). Specify cable length
- cable extension for SR30-D1, 20 m length, with male and female M12-A connectors (order number C07E-20)
- levelling mount for SR30-D1, for spring-loaded levelling and mounting SR30-D1 on a surface (order number LM01)
- tube levelling mount for SR30-D1, for spring-loaded levelling and mounting SR30-D1 on a tube (order number TLM01)
- lower clamp for tube mount
- pair of M5x30 bolts for tube mount
- pair of M5x45 bolts for tube mount

NOTE: Outer dome, bubble level, thermopile sensor and internal sensors of SR30-D1 cannot be supplied as spare parts. In case of damage to the SR30-D1, after repair the instrument must be tested to verify performance within specification limits. This is required by ISO 9060. Testing involves verification of the directional response after dome, thermal sensor and level replacement and verification of the temperature response after thermal sensor replacement.

### 10.4 Appendix on the ventilator

The nominal ventilator speed is 7400 RPM at 20 °C. Depending on operating conditions the speed may vary. The normal startup time is one minute. At temperatures below -10 °C the startup time may increase to several minutes and the ventilator speed may drop. The slow startup does not affect the lifetime in of the ventilator. Variations of the fan speed do not affect the instrument performance. The ventilator life expectancy  $L_{10\%}$  is 70,000 hours and the MTBF (Mean Time Between Failure) is 350,000 hours when continuously operated at 40 °C. Therefore we specify a lifetime of > 5 years for the ventilator under typical operating conditions.

The recommended operation is either continuously [ON] or continuously [OFF]. Switching [ON] and [OFF] frequently (for example daily) reduces the ventilator lifetime. In case the ventilator speed is < 5000 RPM at 20 °C consistently, there may be a problem and fan replacement may be needed. Factors that may negatively impact the fan life time are:

- long operation at elevated temperatures, especially above +70 °C
- frequently (re-)starting the ventilator
- excessive mechanical shocks and vibrations

## 10.5 Appendix on standards for classification and calibration

Both ISO and ASTM have standards on instrument classification and methods of calibration. The World Meteorological Organisation (WMO) has largely adopted the ISO classification system.

**Table 10.5.1** *Pyranometer standardisation in ISO and ASTM*

<b>STANDARDS ON INSTRUMENT CLASSIFICATION AND CALIBRATION</b>	
ISO STANDARD	EQUIVALENT ASTM STANDARD
ISO 9060:1990 Solar energy -- Specification and classification of instruments for measuring hemispherical solar and direct solar radiation	not available Comment: work is in progress on a new ASTM equivalent standard
Comment: a standard "Solar energy --Methods for testing pyranometer and pyrhelimeter characteristics" has been announced in ISO 9060 but is not yet implemented.	not available
ISO 9846:1993 Solar energy -- Calibration of a pyranometer using a pyrhelimeter	ASTM G167 - 05 Standard Test Method for Calibration of a Pyranometer Using a Pyrhelimeter
ISO 9847:1992 Solar energy -- Calibration of field pyranometers by comparison to a reference pyranometer	ASTM E 824 -10 Standard Test Method for Transfer of Calibration from Reference to Field Radiometers  ASTM G207 - 11 Standard Test Method for Indoor Transfer of Calibration from Reference to Field Pyranometers
ISO 9059:1990 Solar energy -- Calibration of field pyrhelimeters by comparison to a reference pyrhelimeter	ASTM E 816 Standard Test Method for Calibration of Pyrhelimeters by Comparison to Reference Pyrhelimeters

## 10.6 Appendix on calibration hierarchy

The World Radiometric Reference (WRR) is the measurement standard representing the SI unit of irradiance. Use of WRR is mandatory when working according to the standards of both WMO and ISO. ISO9874 states under paragraph 1.3: the methods of calibration specified are traceable to the WRR. The WMO manual states under paragraph 7.1.2.2: the WRR is accepted as representing the physical units of total irradiance.

The worldwide homogeneity of the meteorological radiation measurements is guaranteed by the World Radiation Center in Davos Switzerland, by maintaining the World Standard Group (WSG) which materialises the World Radiometric Reference.

See [www.pmodwrc.ch](http://www.pmodwrc.ch)

The Hukseflux standard is traceable to an outdoor WRR calibration. Some small corrections are made to transfer this calibration to the Hukseflux standard conditions: sun at zenith and 1000 W/m<sup>2</sup> irradiance level. During the outdoor calibration the sun is typically at 20 to 40 ° zenith angle, and the total irradiance at a 700 W/m<sup>2</sup> level.

**Table 10.6.1** *Calibration hierarchy for pyranometers*

---

#### **WORKING STANDARD CALIBRATION AT PMOD / WRC DAVOS**

---

Calibration of working standard pyranometers:

Method: ISO 9846, type 1 outdoor. This working standard has an uncertainty "uncertainty of standard". The working standard has been calibrated under certain "test conditions of the standard". The working standard has traceability to WRR world radiometric reference.

---

#### **CORRECTION OF (WORKING) STANDARD CALIBRATION TO STANDARDISED REFERENCE CONDITIONS**

---

Correction from "test conditions of the standard" to "reference conditions" i.e. to normal incidence and 20 °C:

Using known (working) standard pyranometer properties: directional, non linearity, offsets, temperature dependence). This correction has an uncertainty; "uncertainty of correction".

At Hukseflux we also call the working standard pyranometer "standard".

---

#### **INDOOR PRODUCT CALIBRATION**

---

Calibration of products, i.e. pyranometers:

Method: according to ISO 9847, Type IIc, which is an indoor calibration.

This calibration has an uncertainty associated with the method.

(In some cases like the BSRN network the product calibration is with a different method; for example again type 1 outdoor)

---

#### **CALIBRATION UNCERTAINTY CALCULATION**

---

ISO 98-3 Guide to the Expression of Uncertainty in Measurement, GUM Determination of combined expanded uncertainty of calibration of the product, including uncertainty of the working standard, uncertainty of correction, uncertainty of the method (transfer error). The coverage factor must be determined; at Hukseflux we work with a coverage factor  $k = 2$ .

---

## 10.7 Appendix on meteorological radiation quantities

A pyranometer measures irradiance. The time integrated total is called radiant exposure. In solar energy radiant exposure is often given in  $W \cdot h/m^2$ .

**Table 10.7.1** Meteorological radiation quantities as recommended by WMO (additional symbols by Hukseflux Thermal Sensor). POA stands for Plane of Array irradiance. The term originates from ASTM and IEC standards.

SYMBOL	DESCRIPTION	CALCULATION	UNITS	ALTERNATIVE EXPRESSION	
$E_{\downarrow}$	downward irradiance	$E_{\downarrow} = E_{g\downarrow} + E_{i\downarrow}$	$W/m^2$		
$H_{\downarrow}$	downward radiant exposure for a specified time interval	$H_{\downarrow} = H_{g\downarrow} + H_{i\downarrow}$	$J/m^2$		
$E_{\uparrow}$	upward irradiance	$E_{\uparrow} = E_{g\uparrow} + E_{i\uparrow}$	$W/m^2$		
$H_{\uparrow}$	upward radiant exposure for a specified time interval	$H_{\uparrow} = H_{g\uparrow} + H_{i\uparrow}$	$J/m^2$	$W \cdot h/m^2$	Change of units
$E$	direct solar irradiance normal to the apparent solar zenith angle		$W/m^2$	DNI	Direct Normal Irradiance
$E_0$	solar constant		$W/m^2$		
$E_{g\downarrow h}$	global irradiance; hemispherical irradiance on a specified, in this case horizontal surface.*	$E_{g\downarrow} = E \cos \theta_h + E_{d\downarrow}$	$W/m^2$	GHI	Global Horizontal Irradiance
$E_{g\downarrow t}$	global irradiance; hemispherical irradiance on a specified, in this case tilted surface.*	$E_{g\downarrow} = E \cdot \cos \theta_t + E_{d\downarrow t} + E_{r\uparrow t}$ ***	$W/m^2$	POA	Plane of Array
$E_{d\downarrow}$	downward diffuse solar radiation		$W/m^2$	DHI	Diffuse Horizontal Irradiance
$E_{i\uparrow}, E_{i\downarrow}$	upward / downward long-wave irradiance		$W/m^2$		
$E_{r\uparrow}$	reflected solar irradiance		$W/m^2$		
$E^*$	net irradiance	$E^* = E_{\downarrow} - E_{\uparrow}$	$W/m^2$		
$T_{\downarrow}$	apparent surface temperature**		$^{\circ}C$ or $K$		
$T_{\uparrow}$	apparent sky temperature**		$^{\circ}C$ or $K$		
SD	sunshine duration		h		

$\theta$  is the apparent solar zenith angle  $\theta_h$  relative to horizontal,  $\theta_t$  relative to a tilted surface

g = global, l = long wave, t = tilted \*, h = horizontal\*

\* distinction horizontal and tilted from Hukseflux,

\*\* T symbols introduced by Hukseflux,

\*\*\* contributions of  $E_{d\downarrow t}$  and  $E_{r\uparrow t}$  are  $E_{d\downarrow}$  and  $E_{r\uparrow}$  both corrected for the tilt angle of the surface

## 10.8 Appendix on ISO and WMO classification tables

**Table 10.8.1** Classification table for pyranometers per ISO 9060 and WMO.

*NOTE: WMO specification of spectral selectivity is different from that of ISO. Hukseflux conforms to the ISO limits. WMO also specifies expected accuracies. ISO finds this not to be a part of the classification system because it also involves calibration. Please note that WMO achievable accuracies are for clear days at mid latitudes and that the uncertainty estimate does not include uncertainty due to calibration\*.*

<b>ISO CLASSIFICATION** TABLE</b>			
ISO CLASS	SECONDARY STANDARD	FIRST CLASS	SECOND CLASS
Specification limit			
Response time (95 %)	15 s	30 s	60 s
Zero offset a (response to 200 W/m <sup>2</sup> net thermal radiation)	+ 7 W/m <sup>2</sup>	+ 15 W/m <sup>2</sup>	+ 30 W/m <sup>2</sup>
Zero offset b (response to 5 K/h in ambient temperature)	± 2 W/m <sup>2</sup>	± 4 W/m <sup>2</sup>	± 8 W/m <sup>2</sup>
Non-stability (change per year)	± 0.8 %	± 1.5 %	± 3 %
Non-linearity (100 to 1000 W/m <sup>2</sup> )	± 0.5 %	± 1 %	± 3 %
Directional response	± 10 W/m <sup>2</sup>	± 20 W/m <sup>2</sup>	± 30 W/m <sup>2</sup>
Spectral selectivity (350 to 1 500 x 10 <sup>-9</sup> m) (WMO 300 to 3 000 x 10 <sup>-9</sup> m)	± 3 %	± 5 %	± 10 %
Temperature response (interval of 50 K)**	2 %	4 %	8 %
Tilt response (0 to 90 ° at 1000 W/m <sup>2</sup> )	± 0.5 %	± 2 %	± 5 %
<b>ADDITIONAL WMO SPECIFICATIONS</b>			
WMO CLASS	HIGH QUALITY	GOOD QUALITY	MODERATE QUALITY
WMO: achievable accuracy for daily sums*	2 %	5 %	10 %
WMO: achievable accuracy for hourly sums*	3 %	8 %	20 %
WMO: achievable accuracy for minute sums*	not specified	not specified	not specified
WMO: resolution (smallest detectable change)	1 W/m <sup>2</sup>	5 W/m <sup>2</sup>	10 W/m <sup>2</sup>
<b>CONFORMITY TESTING***</b>			
ISO 9060	individual instrument only: all specs must comply	group compliance	group compliance

\* WMO 7.2.1: The estimated uncertainties are based on the following assumptions: (a) instruments are well-maintained, correctly aligned and clean; (b) 1 min and 1 h figures are for clear-sky irradiances at solar noon; (c) daily exposure values are for clear days at mid-latitudes. WMO 7.3.2.5: Table 7.5 lists the expected maximum deviation from the true value, excluding calibration errors.

\*\* At Hukseflux the expression ± 1 % is used instead of a range of 2 %.



\*\*\* an instrument is subject to conformity testing of its specifications. Depending on the classification, conformity compliance can be proven either by group- or individual compliance. A specification is fulfilled if the mean value of the respective test result does not exceed the corresponding limiting value of the specification for the specific category of instrument.

## 10.9 Appendix on definition of pyranometer specifications

**Table 10.9.1** Definition of pyranometer specifications (continued on next page)

SPECIFICATION	DEFINITION	SOURCE
Response time (95 %)	time for 95 % response. The time interval between the instant when a stimulus is subjected to a specified abrupt change and the instant when the response reaches and remains within specified limits around its final steady value. The response time is a measure of the thermal inertia inherent in the stabilization period for a final reading.	ISO 9060-1990 WMO 1.6.3
Zero offset a: (200 W/m <sup>2</sup> net thermal radiation )	response to 200 W/m <sup>2</sup> net thermal radiation (ventilated). Hukseflux assumes that unventilated instruments have to specify the zero-offset in unventilated – worst case – conditions. Zero offsets are a measure of the stability of the zero-point. Zero offset a is visible at night as a negative offset, the instrument dome irradiates in the far infra red to the relatively cold sky. This causes the dome to cool down. The pyranometer sensor irradiates to the relatively cool dome, causing a negative offset. Zero offset a is also assumed to be present during daytime.	ISO 9060-1990
Zero offset b: (5 K/h in ambient temperature)	response to 5 K/h change in ambient temperature. Zero offsets are a measure of the stability of the zero-point.	ISO 9060-1990
Non-stability (change per year)	percentage change in sensitivity per year. The dependence of sensitivity resulting from ageing effects which is a measure of the long-term stability.	ISO 9060-1990
Non-linearity (100 to 1000 W/m <sup>2</sup> )	percentage deviation from the sensitivity at 500 W/m <sup>2</sup> due to the change in irradiance within the range of 100 W/m <sup>2</sup> to 1000 W/m <sup>2</sup> . Non-linearity has an overlap with directional response, and therefore should be handled with care in uncertainty evaluation.	ISO 9060-1990
Directional response	the range of errors caused by assuming that the normal incidence sensitivity is valid for all directions when measuring from any direction a beam radiation whose normal incidence irradiance is 1000 W/m <sup>2</sup> . Directional response is a measure of the deviations from the ideal "cosine behaviour" and its azimuthal variation.	ISO 9060-1990
Spectral selectivity (350 to 1500 x 10 <sup>-9</sup> m) (WMO 300 to 3000 x 10 <sup>-9</sup> m)	percentage deviation of the product of spectral absorptance and spectral transmittance from the corresponding mean within 350 x 10 <sup>-9</sup> m to 1500 x 10 <sup>-9</sup> m and the spectral distribution of irradiance. Spectral selectivity is a measure of the spectral selectivity of the sensitivity.	ISO 9060-1990

Temperature response (interval of 50 K)	percentage deviation of the sensitivity due to change in ambient temperature within an interval of 50 K the temperature of the pyranometer body.	ISO 9060-1990
Tilt response (0° to 90° at 1000 W/m <sup>2</sup> )	percentage deviation from the sensitivity at 0° tilt (horizontal) due to change in tilt from 0 ° to 90 ° at 1000 W/m <sup>2</sup> irradiance. Tilt response describes changes of the sensitivity due to changes of the tilt angle of the receiving surface.	ISO 9060-1990
Sensitivity	the change in the response of a measuring instrument divided by the corresponding change in the stimulus.	WMO 1.6.3
Spectral range	the spectral range of radiation to which the instrument is sensitive. For a normal pyranometer this should be in the 0.3 to 3 x 10 <sup>-6</sup> m range. Some pyranometers with coloured glass domes have a limited spectral range.	Hukseflux

## 10.10 Appendix on terminology / glossary

**Table 10.10.1** Definitions and references of used terms (continued on next page)

TERM	DEFINITION (REFERENCE)
Solar energy or solar radiation	solar energy is the electromagnetic energy emitted by the sun. Solar energy is also called solar radiation and shortwave radiation. The solar radiation incident on the top of the terrestrial atmosphere is called extra-terrestrial solar radiation; 97 % of which is confined to the spectral range of 290 to 3 000 x 10 <sup>-9</sup> m. Part of the extra-terrestrial solar radiation penetrates the atmosphere and directly reaches the earth's surface, while part of it is scattered and / or absorbed by the gas molecules, aerosol particles, cloud droplets and cloud crystals in the atmosphere. The former is the direct component, the latter is the diffuse component of the solar radiation. (ref: WMO, Hukseflux)
Hemispherical solar radiation	solar radiation received by a plane surface from a 180 ° field of view angle (solid angle of 2 π sr).(ref: ISO 9060)
Global solar radiation	the solar radiation received from a 180 ° field of view angle on a horizontal surface is referred to as global radiation. Also called GHI. This includes radiation received directly from the solid angle of the sun's disc, as well as diffuse sky radiation that has been scattered in traversing the atmosphere. (ref: WMO) Hemispherical solar radiation received by a horizontal plane surface. (ref: ISO 9060)
Plane-of-array irradiance	also POA: hemispherical solar irradiance in the plane of a PV array. (ref: ASTM E2848-11 / IEC 61724)
Direct solar radiation	radiation received from a small solid angle centred on the sun's disc, on a given plane. (ref: ISO 9060)
Terrestrial or Longwave radiation	radiation not of solar origin but of terrestrial and atmospheric origin and having longer wavelengths (3 000 to 100 000 x 10 <sup>-9</sup> m). In case of downwelling E <sub>i</sub> ↓ also the background radiation from the universe is involved, passing through the "atmospheric window". In case of upwelling E <sub>i</sub> ↑, composed of long-wave electromagnetic energy emitted by the earth's surface and by the gases, aerosols and clouds of the atmosphere; it is also partly absorbed within the atmosphere. For a temperature of 300 K, 99.99 % of the power of the terrestrial radiation has a wavelength longer than 3 000 x 10 <sup>-9</sup> m and about 99 per cent longer than 5 000 x 10 <sup>-9</sup> m. For lower temperatures, the spectrum shifts to longer wavelengths. (ref: WMO)
World	measurement standard representing the SI unit of irradiance with an uncertainty

Radiometric Reference (WRR)	of less than $\pm 0.3\%$ (see the WMO Guide to Meteorological Instruments and Methods of Observation, 1983, subclause 9.1.3). The reference was adopted by the World Meteorological Organization (WMO) and has been in effect since 1 July 1980. (ref: ISO 9060)
Albedo	ratio of reflected and incoming solar radiation. Dimensionless number that varies between 0 and 1. Typical albedo values are: $< 0.1$ for water, from 0.1 for wet soils to 0.5 for dry sand, from 0.1 to 0.4 for vegetation, up to 0.9 for fresh snow.
Angle of incidence	angle of radiation relative to the sensor measured from normal incidence (varies from $0^\circ$ to $90^\circ$ ).
Zenith angle	angle of incidence of radiation, relative to zenith. Equals angle of incidence for horizontally mounted instruments
Azimuth angle	angle of incidence of radiation, projected in the plane of the sensor surface. Varies from $0^\circ$ to $360^\circ$ . 0 is by definition the cable exit direction, also called north, east is $+90^\circ$ . (ASTM G113-09)
Sunshine duration	sunshine duration during a given period is defined as the sum of that sub-period for which the direct solar irradiance exceeds $120 \text{ W/m}^2$ . (ref: WMO)

## 10.11 Appendix on floating point format conversion

For efficient use of microcontroller capacity some registers in the SR30 contain data in a *float or floating point* format. In fact, a floating point is an approximation of a real number represented by a number of significant digits (*mantissa*) and an exponent. For implementation of the floating point numbers, Hukseflux follows the IEEE 754 standard. In this example the floating point of register 41 and 42 is converted to the decimal value it represents. In the Sensor Manager software and other Modbus tools, floating point data will be converted to decimal data automatically.

Example of the calculation of register 41 + 42 representing a floating point for the sensitivity of the sensor, which is 15.14:

Data in register 41, 16754 (MSW)

Data in register 42, 15729 (LSW)

Double word:

$(MSW \times 2^{16}) + LSW$  so:  $(16754 \times 2^{16}) + 15729 = 1098005873$

According to IEEE 754:

Sign bit:

$1098005873 < 2147483647$  so: sign bit = 1;

The number 2147483647 is defined by IEEE 754

Exponent:

$1098005873 / 2^{23} = 130$  (digits after the decimal point are ignored)

$130 - 127 = 3$  so: exponent = 3;

The number 127 is a constant defined by IEEE 754

Mantissa:

$130 \times 2^{23} = 1090519040$

$1098005873 - 1090519040 = 7486833$

$7486833 / 2^{23} = 0.8925$

According to IEEE 754, 1 has to be added to get mantissa

$0.8925 + 1 = 1.8925$  so: mantissa = 1.8925

Calculation of floating point:

$\text{float} = \text{sign bit} \times \text{mantissa} \times (2^{\text{exponent}}) = 1 \times 1.8925 \times 2^3 = 15.14$

so: floating point = 15.14

## 10.12 Appendix on function codes, register and coil overview

**Table 10.12.1** Supported Modbus function codes

SUPPORTED MODBUS FUNCTION CODES	
FUNCTION CODE (HEX)	DESCRIPTION
0x01	Read Coils
0x02	Read Discrete Inputs
0x03	Read Holding Registers
0x04	Read Input Register
0x05	Write Single Coil
0x06	Write Single Holding Register
0x0F	Write Multiple Coils
0x10	Write Multiple Registers



Your data request may need an offset of +1 for each SR30-D1 register number, depending on processing by the network master. Example: SR30-D1 register number 7 + master offset = 7 + 1 = master register number 8. Consult the manual of the device acting as the local master.

**Table 10.12.2** Modbus registers 0 to 199

MODBUS REGISTERS 0-199				
REGISTER NUMBER	PARAMETER	DESCRIPTION OF CONTENT	TYPE OF	FORMAT OF DATA
0	Modbus address	Sensor address in Modbus network, default = 1	R/W	U16
1	Serial communication settings	Sets the serial communication, default = 5	R/W	U16
2 + 3	Irradiance (temperature compensated signal)	Temperature compensated signal in $\times 0.01 \text{ W/m}^2$	R	S32
4 + 5	Irradiance (uncompensated signal)	Uncompensated signal in $\times 0.01 \text{ W/m}^2$	R	S32
6	Sensor body temperature	In $\times 0.01 \text{ }^\circ\text{C}$	R	S16
7	Sensor electrical resistance	In $\times 0.1 \text{ } \Omega$	R	U16
8	Scaling factor irradiance	Default = 100	R	U16
9	Scaling factor temperature	Default = 100	R	U16

**MODBUS REGISTERS 0 – 199, continued**

REGISTER NUMBER	PARAMETER	DESCRIPTION OF CONTENT	TYPE OF	FORMAT OF DATA
10 + 11	Sensor voltage output	In x 10 <sup>-9</sup> V	R	S32
12 to 31	Factory use only			
32 to 35	Sensor model	Part one of sensor description	R	String
36 to 39	Sensor model	Part two of sensor description	R	String
40	Sensor serial number		R	U16
41 + 42	Sensor sensitivity	In x 10 <sup>-6</sup> V/(W/m <sup>2</sup> )	R	Float
43	Response time	In x 0.1 s	R	U16
44	Sensor resistance	In x 0.1 Ω	R	U16
45	Reserved	Always 0	R	U16
46 + 47	Sensor calibration date	Calibration date of the sensor in YYYYMMDD	R	U32
48 to 60	Factory use			
61	Firmware version		R	U16
62	Hardware version		R	U16
63 + 64	Sensor sensitivity history 1	In x 10 <sup>-6</sup> V/(W/m <sup>2</sup> ) Default value is 0	R	Float
65 + 66	Calibration date history 1	Former calibration date of the sensor in YYYYMMDD Default value is 0	R	U32
67 + 68	Sensor sensitivity history 2	See register 63 + 64	R	Float
69 + 70	Calibration date history 2	See register 65 + 66	R	U32
71 + 72	Sensor sensitivity history 3	See register 63 + 64	R	Float
73 + 74	Calibration date history 3	See register 65 + 66	R	U32
75 + 76	Sensor sensitivity history 4	See register 63 + 64	R	Float
77 + 78	Calibration date history 4	See register 65 + 66	R	U32
79 + 80	Sensor sensitivity history 5	See register 63 + 64	R	Float
81 + 82	Calibration date history 5	See register 65 + 66	R	U32
83 + 84	Directional response measurement date	Directional response measurement date in YYYYMMDD	R	U32

<b>MODBUS REGISTERS 0 – 199, continued</b>				
REGISTER NUMBER	PARAMETER	DESCRIPTION OF CONTENT	TYPE OF	FORMAT OF DATA
85	Directional response measurement employee		R	U16
86	Temperature response	In x 0.01 %	R	S16
87 + 88	Polynomial temperature coefficient a		R	Float
89 + 90	Polynomial temperature coefficient b		R	Float
91 + 92	Polynomial temperature coefficient c		R	Float
93 + 94	Temperature response characterisation measurement date	Temperature response characterisation measurement date of the sensor in YYYYMMDD.	R	U32
95	Temperature response characterisation measurement employee		R	U16
96 + 97	Factory use only			
98	Humidity	In x 0.01 %	R	U16
99	Humidity temperature	In x 0.01 °C	R	S16
100-136	Factory use			
137	Pressure	In x (1/32) mbar	R	U16
138	Pressure average	In x (1/32) mbar	R	U16
139	Pressure temperature	In x (1/256) °C	R	S16
140	Pressure temperature average	In x (1/256) °C	R	S16
141 - 193	Factory use			
194	Tilt angle	In x 0.01 °	R	U16
195	Tilt angle average	In x 0.01 °	R	U16
196	Fan speed RPM	In x 1 RPM	R	U16
197	Factory use			
198	Heater current	In x 1 mA	R	U16
199	Fan current	In x 1 mA	R	U16

Note 1: Up to five 16 bit registers can be requested in one request. If requesting six or more registers, use multiple requests.



Please note that if your data request needs an offset of +1 for each SR30-D1 register number, depending on processing by the network master, this offset applies to coils as well. Consult the manual of the device acting as the local master.

**Table 10.12.3** *Coils*

COILS				
COIL	PARAMETER	DESCRIPTION	TYPE OF	OBJECT TYPE
0	Restart	Restart the sensor	W	Single bit
1	Heater	Turn heater on/off	W	Single bit
2	Check	Measure sensor electrical resistance	W	Single bit
3	Fan	Turn fan on/off	W	Single bit



### 10.13 EU declaration of conformity



We, Hukseflux Thermal Sensors B.V.  
Delftechpark 31  
2628 XJ Delft  
The Netherlands

in accordance with the requirements of the following directive:

2014/30/EU The Electromagnetic Compatibility Directive

hereby declare under our sole responsibility that:

Product model: SR30-D1  
Product type: Pyranometer

has been designed to comply and is in conformity with the relevant sections and applicable requirements of the following standards:

Emission: IEC/EN 61000-6-1, Class B, RF emission requirements, IEC CISPR11  
and EN 55011 Class B requirements  
Immunity: IEC/EN 61000-6-2 and IEC 61326 requirements  
Report: "EMC test SR30-D1 2027 v28122016", 2 January 2017



Eric HOEKSEMA  
Director  
Delft  
06 January, 2017



